

Guide  
September 2000



J D E D W A R D S ®

# Enterprise Workflow Management

Release  
OneWorld® Xe





J.D. Edwards World Source Company  
One Technology Way  
Denver, CO 80237

Copyright ©J.D. Edwards World Source Company, 1998 - 2000  
All Rights Reserved

J.D. Edwards is a registered trademark of J.D. Edwards & Company. The names of all other products and services of J.D. Edwards used herein are trademarks or registered trademarks of J.D. Edwards World Source Company.

All other product names used are trademarks or registered trademarks of their respective owners.

The information in this guide is confidential and a proprietary trade secret of J.D. Edwards World Source Company. It may not be copied, distributed, or disclosed without prior written permission. This guide is subject to change without notice and does not represent a commitment on the part of J.D. Edwards & Company and/or its subsidiaries. The software described in this guide is furnished under a license agreement and may be used or copied only in accordance with the terms of the agreement. J.D. Edwards World Source Company uses automatic software disabling routines to monitor the license agreement. For more details about these routines, please refer to the technical product documentation.



# Table of Contents

---

<b>Why Workflow Management Is Important</b> .....	<b>1-1</b>
Workflow Management: Streamlining Business .....	1-1
The Benefits of Workflow Management .....	1-2
Workflow Enhancement Scenario .....	1-3
Conventional Workflow .....	1-3
Enhanced Workflow with Enterprise Workflow Management ...	1-6
J.D. Edwards Brings Ideas to Action .....	1-7
<b>Enterprise Workflow Management Overview</b> .....	<b>2-1</b>
Enterprise Workflow Technology .....	2-2
Workflow Features .....	2-4
The Components of a OneWorld Workflow Process .....	2-4
Example of a Workflow Process .....	2-8
<b>Planning for Workflow</b> .....	<b>3-1</b>
Creating a Diagram of an Organizational Schematic .....	3-1
Identifying Candidate Processes for Workflow .....	3-2
Designing Process Prototypes .....	3-3
<b>Workflow Setup</b> .....	<b>4-1</b>
Setting Up Message Templates .....	4-3
Setting Up Queues .....	4-9
Setting Up External Mail Access .....	4-15
Simple Mail Transfer Protocol .....	4-15
Benefits of Using an SMTP Server .....	4-16
Messaging Application Programming Interface .....	4-16
Setting Up a Third-Party Mail System .....	4-16
<b>Creating Workflow Processes</b> .....	<b>5-1</b>
Creating a Workflow Process .....	5-3
Understanding Key Data and Additional Data .....	5-3
Workflow Key Data and Additional Data Naming Conventions .	5-4
Naming a Workflow Process .....	5-5
Activating a Workflow Process .....	5-7
Specifying Key Data and Additional Data .....	5-7
Adding Activities to a Process .....	5-10
Adding a Function Activity .....	5-10
Adding a Run Executable Activity .....	5-13
Adding a Batch Application Activity .....	5-15
Adding a Recipient Condition Activity .....	5-18
Adding a Message Activity .....	5-19
Adding a Halt Process Activity .....	5-26
Adding an Interactive Application Activity .....	5-27

Adding a Process Activity .....	5-30
Adding Activity Conditions .....	5-32
Joining Activities .....	5-33
Understanding Distribution Lists .....	5-35
Threshold Values .....	5-35
Routing Options .....	5-36
Escalation Hours and Minutes .....	5-37
Structure Types .....	5-38
Single-Level Distribution List Structure .....	5-38
Multiple-Level Distribution List Structure .....	5-39
Setting Up Distribution Lists .....	5-41
Distribution List Guidelines .....	5-41
Adding Recipient Rules .....	5-51
How Recipient Rules Work .....	5-51
How Distribution Lists and Structure Types Work .....	5-52
Distribution List Only .....	5-52
Structure Type Only .....	5-53
Distribution List and Structure Type .....	5-54
Adding a Recipient Rule .....	5-55
Resequencing Activities .....	5-57
Activating a Workflow Process .....	5-61
Attaching a Process to an Application .....	5-63
<b>Using Visio to Set Up Workflow Processes .....</b>	<b>6-1</b>
Setting Up Workflow Activities in Visio .....	6-3
Specifying Visio as the Design Interface .....	6-3
Attaching Activities to a Process in Visio .....	6-3
Attaching Activity Conditions to Activities in Visio .....	6-5
Attaching a Plain Connector to Activities in Visio .....	6-7
Viewing Activity Condition Text in Visio .....	6-7
Working with an Existing Workflow Process in Visio .....	6-9
Modifying a Process and its Activities in Visio .....	6-9
Viewing Subprocesses in Visio .....	6-10
Using Editing Tools in Visio .....	6-13
Using the Magnification Option .....	6-13
Viewing the Ruler, the Grid, and the Guides .....	6-13
Printing Activity Condition Text .....	6-14
Moving Connectors .....	6-15
<b>Administrative Tasks .....</b>	<b>7-1</b>
Monitoring Process Activity .....	7-3
Reviewing a Process Status .....	7-3
Terminating, Suspending, or Resuming an Instance of a Process ...	7-5
Reviewing Attachments to an Activity .....	7-5
Overriding the Message Approval Process .....	7-6
Changing Queue Security .....	7-7
Specifying the Queues that a User Can View in a Group .....	7-7
Changing Public Security .....	7-9

Activating the Escalation Monitor .....	7-11
Analyzing Workflow Processes .....	7-13
Printing Process Instance Reports .....	7-19
Purging Workflow Data Files .....	7-21
Managing Workflow Processes .....	7-23
Workflow Data .....	7-23
Object Specifications .....	7-24
Workflow Deployment Processes .....	7-24
Copying Process Data to Another Source .....	7-25
<b>Workflow Processing .....</b>	<b>8-1</b>
Workflow Boundaries .....	8-3

## Appendices

Appendix A – Workflow Tables .....	A-1
Appendix B – System Functions .....	B-1
Message System Functions .....	B-1
Workflow System Functions .....	B-2
Appendix C – Distribution List Scenarios .....	C-1
Reviewing Distribution List Guidelines .....	C-1
Single-Level Distribution Lists .....	C-1
Multiple-Level Distribution Lists .....	C-4

## Glossary

## Index





## Why Workflow Management Is Important

In the past, companies often benefited greatly from economies of scale, or the reduction of production costs that is achieved with increased output. These economies were possible because companies typically manufactured large quantities of standard products for relatively large and stable consumer groups. However, economies of scale are becoming less important in today's marketplace, due in large part to increasing fragmentation of the consumer base. With so many products available, customers are more discriminating than ever before in their choices and often expect highly complex services to go with the products that they buy.

As a result, the definition of productivity as it relates to business success is rapidly and radically changing. No longer is productivity defined as simply creating more with less. Increasingly, value is linked not to sheer output but to innovation, or the ability to correctly anticipate and creatively respond to new and changing market opportunities. Today, a keen competitive advantage is enjoyed by those organizations that have the flexible business infrastructures and tools in place to quickly develop new products and services and continuously outperform their competitors' time to market.

The dependence of today's business enterprises on innovation and fast delivery of product cannot be overestimated. Consider, for example, the fact that a full 50% of Hewlett Packard's current sales come from new products introduced in the last three years. With this new emphasis on relentless innovation and the advantages that it breeds, successful companies are constantly searching for ways to reshape their corporate structures to streamline their business processes.

## Workflow Management: Streamlining Business

Today, it is clear that goods and services must be produced both faster and smarter through teamwork and efficiency. Only those companies with innovative staff, products, services, and short development cycles will prosper.

Workflow management, a strategy for automating business processes, is a powerful tool for translating the collaborative vision into real-world business applications with clear and measurable paybacks. The aim of workflow management is to streamline the components of various office systems by eliminating unnecessary tasks (thereby saving the time, effort, and costs associated with performing those tasks) and automating the remaining tasks in a process.

Workflow management can be thought of as the effective application of information technologies to internal business processes in order to accelerate the



collaborative and creative processes that drive innovation. The idea behind workflow software technology is to create a single environment to manage the complexity of multiple office automation environments. As software has migrated from individualized solutions with dedicated functionality to integrated groupware solutions, workflow has evolved as a metaphor for the efficient coordination of multiple workgroups using multiple technologies.

Most workflow products support two basic functions. First, they provide tools for mapping out business processes, which may be defined sets of routes, roles, and rules for the movement of documents and tasks. Second, they implement those processes through linkages with a company's computer network, shared databases, and e-mail systems so that information can flow through the organization at a controlled and efficient pace

Following is an illustration of a basic workflow process for approving an increase to a customer's credit limit:

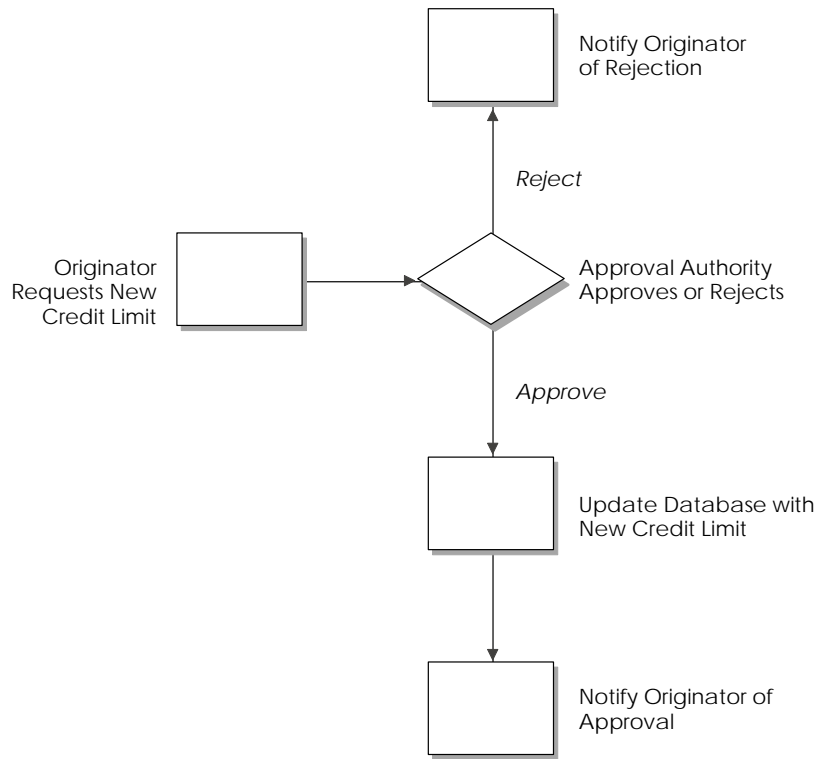

## The Benefits of Workflow Management

Because organizations are made up of a series of intricately intertwined business cycles, these cycles are a logical first place to look when attempting to streamline. According to the Workflow Management Coalition, almost 90% of all time that used to perform tasks within the business setting is classified as transfer time, whereas 10% is used for the actual performance of those tasks. The objective of workflow analysis is to redefine and then reconstruct the

---

components of lengthy business cycles so that the time required to execute a task is minimized and the transfer time between tasks is eliminated entirely.

Other key benefits of workflow management include:

- Improved efficiency through the elimination of many unnecessary task steps
- Better business process control achieved by standardizing work methods and creating audit trails
- Improved customer service when consistency in the processes leads to greater predictability in levels of response to customers
- Flexibility bred from software control over processes, which enables their future redesign in response to changing business needs

## Workflow Enhancement Scenario

Information that is critical to a workflow process can be predefined and stored in database tables, allowing a computer system to automate the flow of information and tasks throughout the enterprise. This automation can minimize the need to rely on physical meetings to re-enter redundant data, and to physically exchange paper. For example, using an automated workflow process, purchase orders; and work orders can be processed to completion without a single printout. The predefined workflow information might include order activity rules, workflow steps, and expenditure authorization requests, all of which can be routed automatically via e-mail.

The following scenario demonstrates the savings in labor and time that can be achieved when workflow management technology is applied to a typical business process like procurement.

### Conventional Workflow

The following graphic illustrates the paper trail of a typical sequential procurement method. Following the graphic is an explanation of the step-by-step tasks of this conventional workflow and the total time required to complete the procurement process.



- 
6. The purchasing clerk reviews the requisition, audits central stores, and sends the requisition to the purchasing manager if the item is in stock, or to the buyer if the item is not in stock.
  7. The buyer reviews the document, selects the supplier, calls for a quote, and passes the requisition to the purchasing manager.
  8. The purchasing manager reviews, signs, and places the requisition in the Out basket.
  9. The purchasing clerk retrieves the requisition and passes it to the encumbrance clerk.
  10. The encumbrance clerk reviews the items, assigns account codes, and checks the budget. If funds are available, the requisition is passed back to the purchasing clerk.
  11. The purchasing clerk sends the requisition to the comptroller if the item is in central stores, or to the buyer if it is not in stock and must be bought and delivered to central stores.
  12. The clerk retrieves the purchase order and delivers it to the comptroller or buyer.
  13. The buyer consolidates the requisition into a single purchase order per vendor and places the order in the out basket for delivery to the comptroller.
  14. The comptroller reviews and signs the purchase order. At this step, the routing can take longer, based on the amount of the request and the level of authorization of the person approving the purchase.
  15. The clerk retrieves the document and places it in interoffice mail. Another day lapses.
  16. A multi-part document arrives one day later via interoffice mail in the purchasing department. The purchasing clerk tears out the white copy and sends the rest of the multipart form to central stores.
  17. The purchasing clerk logs and files the white copy.
  18. The central stores clerk retrieves the item from the shelf, tears out the pink copy, places it in the accounts payable stack, and ships the item and the remaining copies to the remote office.
  19. The administrative assistant receives the item, tears out, logs, and files the blue copies, and places the green receiving and yellow accounts payable copy in a courier pack to go back to the central office.
  20. A courier retrieves the pack and returns the green and yellow copies to the central office.
  21. The purchasing clerk attaches the white original and green receiving copies to each other, puts them in the file, and sends the yellow copy to accounts payable.
  22. The accounts payable clerk receives the invoice from central stores, retrieves the open yellow receiver copy from the file, and matches and enters the voucher.

Total time (in minutes) per item if the item is not in stock: 172.5

Total time (in minutes) per item if the item is in stock: 147.5

## Enhanced Workflow with Enterprise Workflow Management

The following graphic illustrates how OneWorld Enterprise Workflow Management enhances this workflow by reducing the paper trail, minimizing redundant data and data entry, and reducing errors or the need to redo work.

### Workflow Enhancement

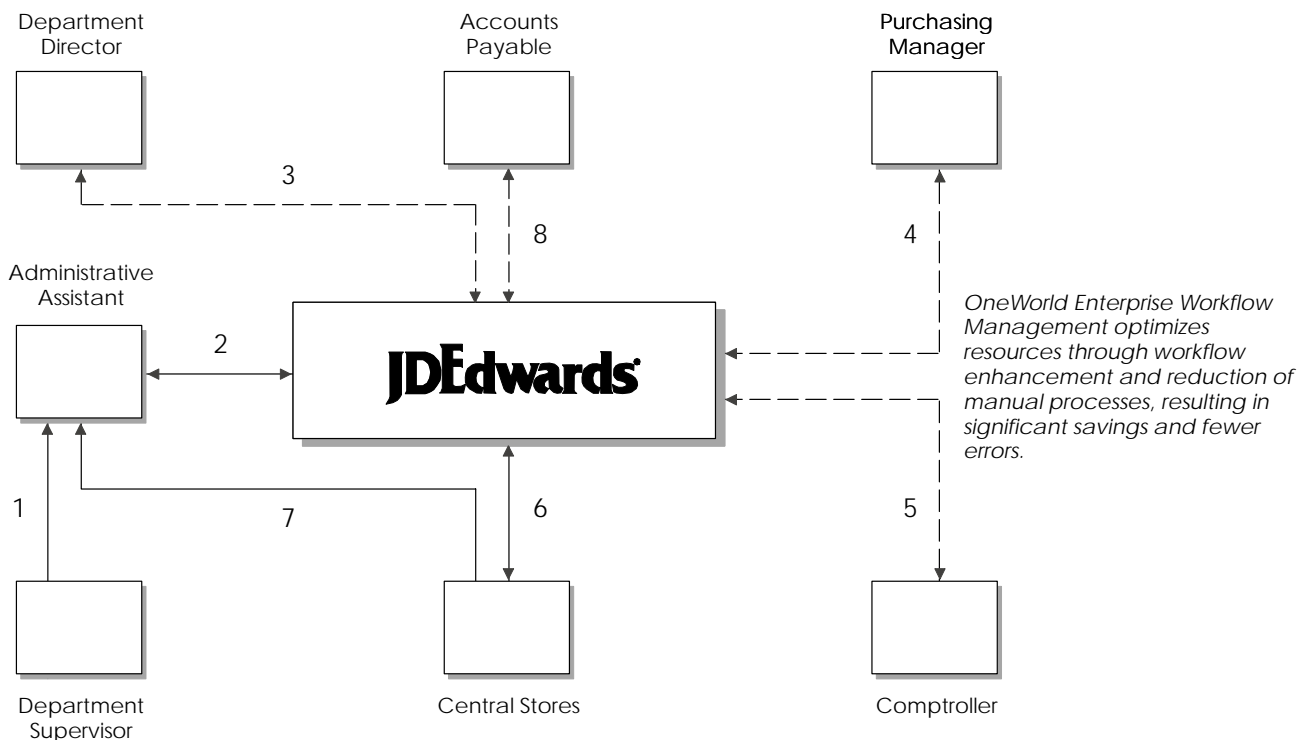

Using Enterprise Workflow Management, the organization streamlined its workflow process as described in the following steps.

- 1 The department supervisor fills out a requisition form to request goods.
- 2 The administrative assistant processes the requisition form online. The system checks the budget and automatically routes the request to the next approver based on the Workflow Table hierarchy and the amount of the item.
- 3 The department director reviews and approves the requisition online. The system automatically routes the requisition to the appropriate buyer or purchasing manager.

- 
- 4 The purchasing manager consolidates the requisition with others for the same vendor into a purchase order. The system automatically routes the purchase order to the next approver.
  - 5 The comptroller reviews and approves the purchase order as required.
  - 6 The purchase order is automatically routed to central stores. A clerk takes the pick slip, retrieves the item from the shelf, and ships it for next-day delivery.
  - 7 The administrative assistant receives the item on the next day.
  - 8 The accounts payable clerk receives the invoice online and matches it to the open receipt that is also online. The system automatically creates a voucher.

Total time (in minutes): 27

## J.D. Edwards Brings Ideas to Action

J.D. Edwards has built a number of useful workflow management tools into OneWorld. With these tools, you can create workflows that can be seamlessly incorporated into your company's business processes.

With J.D. Edwards workflow management tools, you have the power to put your innovative ideas about how to streamline your business tasks quickly and take action. And a year from now, when existing approaches no longer meet market demands, you have the ability to respond quickly and modify your workflows, maintaining your competitive advantage.

### See Also

If you would like to learn more about workflow processes, refer to the following sources:

- *Workflow Strategies*, by James G. Kobiulus, 1997, IDG Books Worldwide, Inc., Foster City, California.
- *The Workflow Imperative*, by Thomas M. Koulopoulos, 1995, John Wiley & Sons, Inc., New York, New York.
- *Workflow Management Coalition*,  
<http://www.aiim.org/wfmc/mainframe.htm>





## Enterprise Workflow Management Overview

OneWorld Enterprise Workflow Management (Workflow) is a means of automating your high-volume, formerly paper-based process into an e-mail-based process flow across a network. Documents, information, and tasks pass from one participant to another for action based on a set of procedural rules. The result is an automated and efficient process with minimal user involvement, which allows you to streamline your existing business processes, to increase efficiency and reduce process time. Moreover, Workflow uses the tools already in place in OneWorld. You can use the OneWorld toolset to easily Workflow-enable any application. This flexibility and ease of use allows you to put new and innovative business process ideas into your existing system without any major changes.

Workflow allows you and your employees to access Workflow messages or tasks from several places, such as:

- Work Center
- Employee Queue Manager
- Third-party e-mail systems

You can monitor your Workflow processes and activities in the following ways:

- From the Workflow administrator's perspective through the Process Activity Monitor. This monitor allows an administrator to override authority at the execution of certain activities or to monitor the activity flow for potential roadblocks in Workflow queues.
- From a user's perspective through the Work Center, which displays action or error messages that require user interaction. For example, when a user receives notification that a document requires his review, the routing and the document appear within the Work Center.

The Workflow model is based on two principles:

### **Routes**

Routes define the path along which the Workflow engine moves work. This work could involve a message, a batch process, a function, an executable, a halt in the system or a form. Routing can be simple, meaning that it is typically sequential; or it can be complex, meaning that it involves joins or splits, parallel routing, or iteratives routing (looping).



**Rules**

Rules define to whom or to where work should be routed. Rules define the conditions that must be met for the Workflow engine to progress from one step to the next. Rules can be contingent upon predefined threshold values, or it can be simple enough to just move to the next step in a process.

Workflow supports the following workflow process:

**Scripted**

Scripted workflow automates business processes that are repetitive or that can be predefined. This type of workflow, which can be highly automated and requires minimal user interaction, can be an approval process or reviewing data in a workbench.

For example, you can script a process in which a user is sent a message to approve or reject an increase to a customer's credit limit. If the user approves the increase, the system updates the customer's credit information in the database. If the user rejects the change, the system retains the old credit information.

## Enterprise Workflow Technology

Workflow incorporates the following technologies:

**Universal routing sheets**

User-defined rules guide the flow of work for a process. For example, when you enter a sales order, you can initiate a customer fulfillment process that includes billing, work order generation, inventory replenishment, forecasting, and scheduling.

**Multiple routing instructions**

Any business process can have a number of workflow routes configured for it, giving your business the flexibility to readily adapt to changing market conditions, as well as handle the inevitable exceptions to the rules. For example, you can specify as many routes as you need to handle purchase orders based on dollar amounts, items, and origin.

---

**Separation of business rules from technology**

A single OneWorld application can adapt to numerous routing situations without requiring programmers to rewrite the source code. Many other integrated applications do not have this flexibility because their workflow processes are hard-coded at installation. In these other applications, constructing different Workflow routes requires programmers to write application code specifically for the different routes. J.D. Edwards Universal Routing Sheet, on the contrary, allows a single application to handle many different situations.

**Workflow queues**

Workflow queues sort messages based on departments within your company and message types. These message types can include action messages, such as approval or rejection messages; error messages, such as notification that a batch process failed to run; and personal mail messages.

**Display and control for Workflow routes**

In addition to a text-based procedure for establishing workflow processes, Workflow incorporates graphical display and control for its processes. This graphical display and control makes establishing processes more intuitive, and therefore easier to set up and modify.

**Media objects and Workflow facilitators**

Workflow is capable of supporting technologies such as OLE objects, imaging, shortcuts to forms, and hotlinks to Web sites to facilitate the flow of a given business process through an enterprise. Scanned text and images can be attached to any Workflow document, which provides your personnel with additional information for decision-making purposes.

**Extended MAPI compliance**

Workflow complies with the Messaging Application Programming Interface (Extended MAPI). Extended MAPI is a Microsoft Windows Open System Architecture (WOSA) that defines messaging system architecture. Extended MAPI defines what the components in a messaging system are and how they behave. It also defines the interface between the messaging system and the components. Extended MAPI also allows messaging components to communicate with incompatible messaging systems.

### Workflow Features

Workflow gives you the ability to do the following:

- Attach a Workflow process with event rules to any event within an application, batch process, or named Event Rules (ER). You can also attach a Workflow process through table event rules in Table Design Aid.
- Execute conditional processing, which is logic contingent upon supplied criteria, such as quantity and dollar amount. This criterion can be any parameter used in the decision-making process that OneWorld can evaluate.
- Create messages specific to the process by setting up message templates (text substitution messages) in the data dictionary.

Workflow also:

- Integrates seamlessly with OneWorld interactive and batch applications
- Offers multiple level approvals
- Offers manual escalation of processes, in which the administrator has the ability to override or bypass certain activities or users in the Workflow process
- Automatically time stamps all activities within a process for improvement analysis and auditing

All of the technology, rules, and principles explained above allow you to work more efficiently and reducing cycle time. The automated process reduces errors and generates less paperwork. Furthermore, OneWorld development tools help you develop Workflow-enabled applications, or quickly and smoothly enable existing applications for Workflow. You have the ability to attach any Workflow process that sends a message or calls an application to any event within an application. All you have to do is attach a Start Process call to an event within an application to initiate the Workflow process. Because this process is defined outside of your application, it offers you unlimited flexibility to incorporate your innovative ideas into OneWorld.

### The Components of a OneWorld Workflow Process

The following graphic illustrates a basic OneWorld Workflow process. The components that make up the process are activities and activity conditions. The Start activity begins the process when triggered by an event within an application, such as someone changing a customer's credit limit. Based on this change, the system sends a message to a designated user (an approver) to review the change, and either approve or reject it. Activity conditions within the process determine which activity will execute based on the approver's response. The lines in the graphic labeled "If Approve" and "If Reject" illustrate the activity conditions.

If the approver approves the change, a business function (a Function activity within the OneWorld Workflow system) updates the database with new information (such as the customer's new credit limit). The system then sends a message back to the originator, acknowledging that the changes were made. If the approver rejects the change, the system sends a message to the originator of the message, informing him or her that the request was rejected. The database remains unchanged if the request is rejected.

A Workflow Process

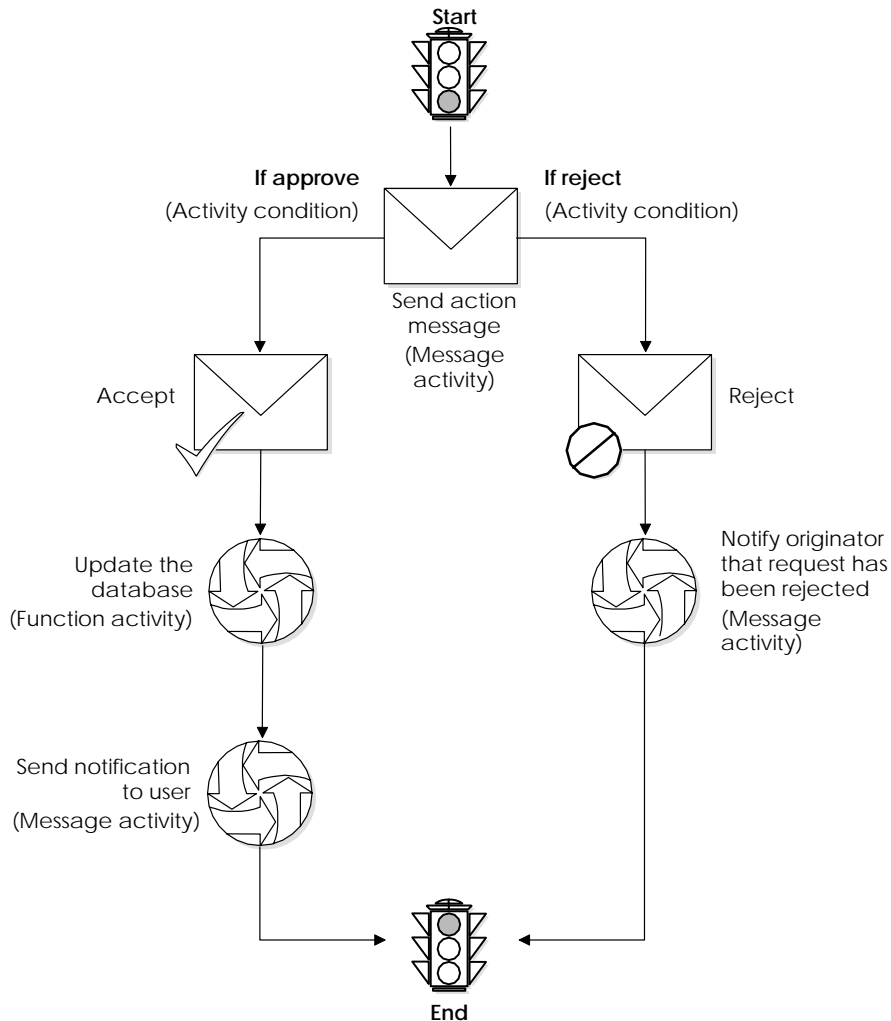

Each icon in this graphic represents an activity that takes place within a process. The following activities may be used in a workflow:

**Start**

This activity is automatically attached to the process when you create a Workflow process.

<b>End</b>	As with Start, this activity is automatically attached to the process when you create a workflow process.
<b>Function</b>	This activity attaches a business function for special logic processing, including any business functions written in C programming language or named event rules. For example, you can set up a function activity that updates the database if a user approves an action message.
<b>Interactive application</b>	This activity starts a OneWorld interactive application, such as Work With Journal Entries.
<b>Message</b>	<p>This activity generates a message based on system functions within OneWorld. You can attach the Generic Approval form (P98805) or any other form. You can also attach a message template that contains values that are substituted from data items within key data and additional data for the workflow.</p> <p>You can mark a message activity as one that will be monitored for escalation. Escalation enables the system to forward, or escalate, unread messages after a certain period of time to another user in a different distribution list. You add escalation to a message so that if the original recipient of the message is not available to respond to the message, another person receives the message instead.</p> <p>The Check for Expired Activities batch process (R98810), which you can start manually or schedule, monitors processes that use escalation.</p>
<b>Run executable</b>	This activity launches an executable program that you specify—for example, a word processing application or spreadsheet.
<b>Batch application</b>	This activity starts a OneWorld batch application.
<b>Process</b>	This activity starts another workflow process, also referred to as a subprocess, which includes its own set of activities.

---

**Halt process**

This activity suspends the process for a certain period of time. Once a period of time has passed or when an event occurs, the process starts again. The process is permanently halted until some outside event restarts it. The date and time specified within the instance record specifies the earliest time that it can be restarted.

The Check for Expired Activities batch process (R98810), which you can start manually or schedule, monitors processes that have been halted.

**Activity condition**

Activity conditions are user-defined rules that determine the next activity. For example, an activity condition called "IFAPPROVE" might trigger the system to invoke the activity to update the database if a user approves a message, and then invoke the activity that sends a message notifying the originator that the message was approved. An activity condition called "IFREJECT" might trigger the system to invoke the activity that sends a message notifying the originator that the message was rejected.

**Recipient condition**

Recipient conditions determine where to send messages. Recipient conditions are used when defining recipient rules. For example, you might set up a recipient condition called ACCTG that uses customer address book numbers as the criterion to determine where to send messages. You could add logic to the recipient condition to tell the system that if the customer number is equal to a range of 1 through 3001, then send messages for those customers to the accounting department distribution list. You can have multiple recipient conditions in a recipient rule.

After a process is activated, the process and activity definitions are protected, thus preventing you from changing the process definitions and activities associated with it while the process is running. Therefore, you cannot attach a new activity to an active process, or change an existing activity. To change a process or activity, you must first deactivate it, or copy an active process and create a new version. The system protects active processes to ensure the integrity and accuracy of the audit data that is generated for the process.

If instances of a process exist, you must copy the process and make changes to the copy or purge the process. See *Purging Workflow Data Files* for more information. If you deactivate a process with instances, you still cannot change it.

The system stamps the time and date of each transaction within the process so that you can analyze each transaction for improvement analysis through the Process Activity Monitor or Advanced Analysis.

See *Monitoring Process Activity* or *Analyzing Workflow Processes* for more information.

## Example of a Workflow Process

The Accounts Receivable system can detect when a OneWorld user changes a customer's credit limit. This ability to detect a change allows for an approval process to automatically route a message to the appropriate people for their approval or rejection.

In the following example, a OneWorld user changes a customer's credit limit from 50,000 USD to 60,000 USD. The system displays a message box that notifies the user that the changes have been submitted for approval. The system does not reflect the new credit limit in the customer record until the change is approved.

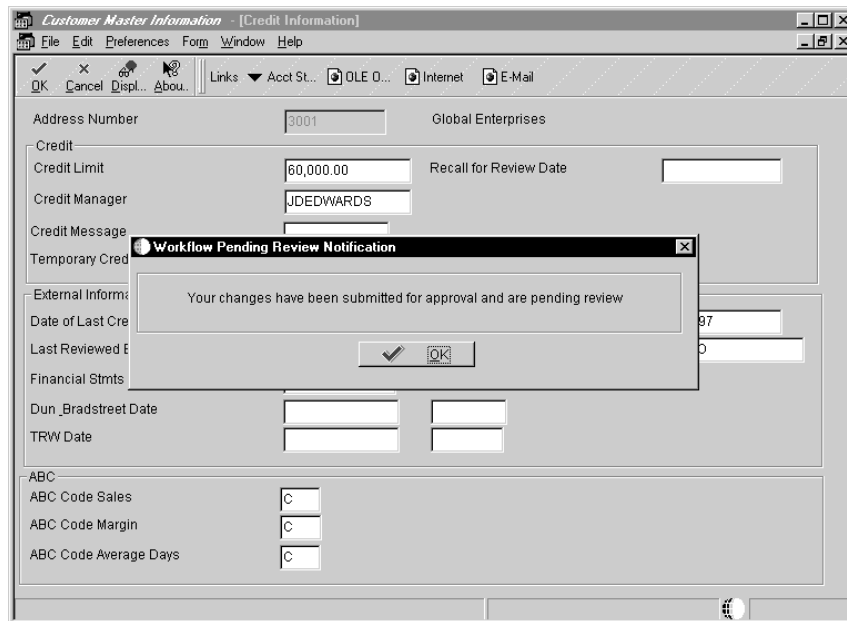

Note that the message shown in this example is specific to the Credit Limit Changed process and does not show up automatically in a process that you set up. You can add a message similar to this one through a form interconnect when you attach a process to an application. See *Attaching a Process to an Application* for more information.

The person who approves the change (the approver) receives a message in the Credit Management Queue through the Employee Work Center. The message indicates that the change is pending approval.

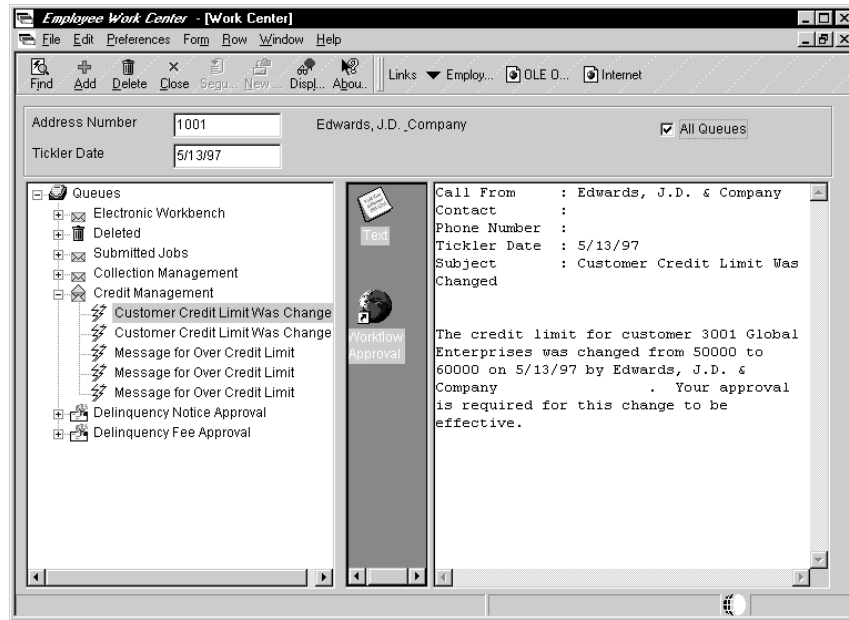

To approve or reject the change, the approver clicks the “Customer Credit Limit Was Changed” message and clicks the Workflow Approval icon, which opens a form used to approve or reject the message. This form also allows the approver to add supplemental information about the approval or rejection action for audit purposes.

If the approver rejects the change, the system clears the message from the queue, which completes the Workflow activity. The system retains the customer’s old credit limit information and sends a message to the originator informing him or her of the rejection.

If the approver approves the change, a function activity initiates a Named Event Rule (NER) that updates the database with the customer’s new credit limit.

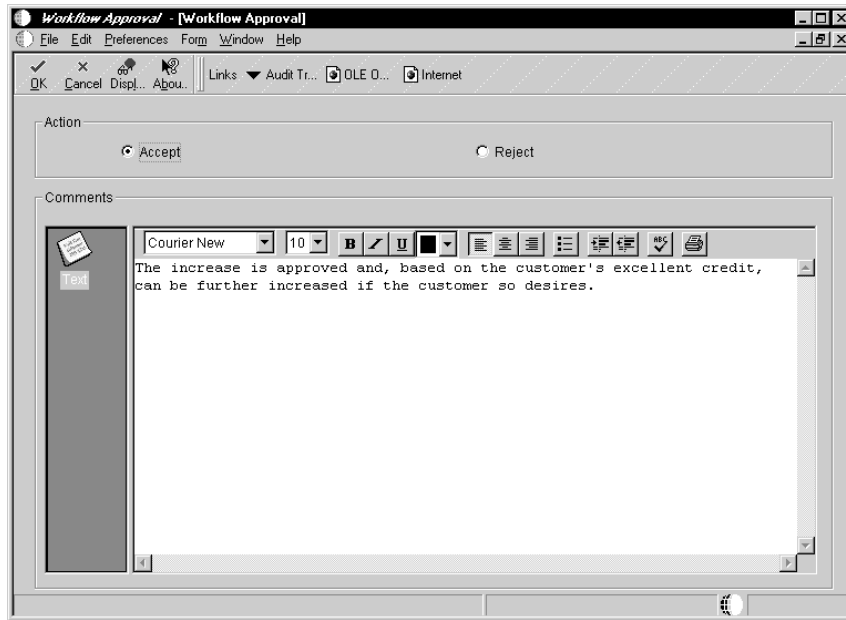

At this point, the process sends a message to the user who originated the credit limit change, indicating that the credit limit change was approved.

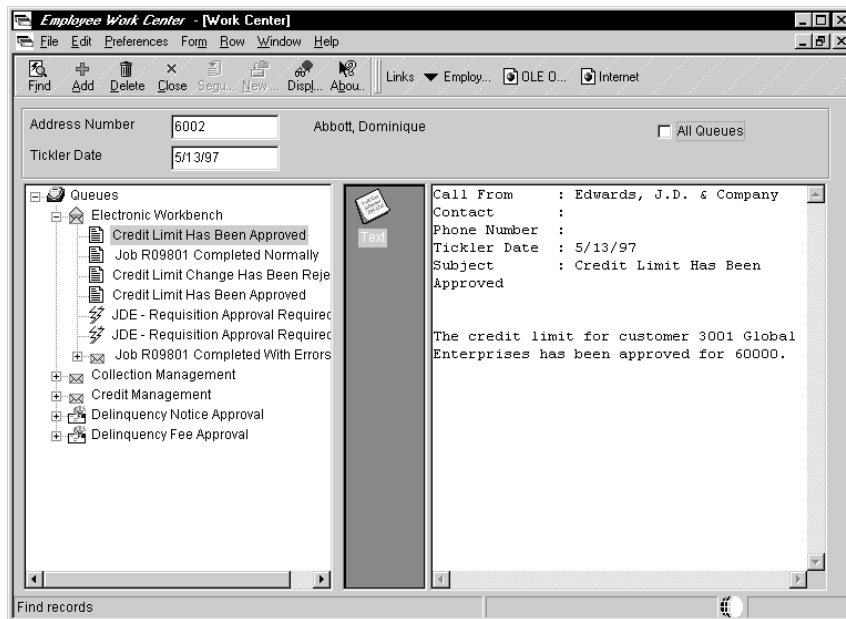



## Planning for Workflow

OneWorld Enterprise Workflow Management (Workflow) is a tool that enables your well-managed business to run even more efficiently. Workflow management is essentially value-neutral, meaning that it does not substantially improve the efficiency of processes that are poorly designed originally. Therefore, before thinking about ways to better manage your internal workflows, your company should first complete some degree of business process reengineering. This planning process is vital to ensure that your current business processes and management approaches are synchronized with today's volatile competitive environment, and not a hindrance to flexibility and growth.

This section discusses:

- Creating a diagram of an organizational schematic
- Identifying candidate processes for workflow
- Designing process prototypes

### Before You Begin

Before you begin creating workflow processes using Workflow, perform the following:

- Understand the concepts of OneWorld development tools. See the *OneWorld Development Tools* guide for more information.
- Define your users and distribution lists in Address Book prior to setting up your Workflow processes. See the *Address Book* guide for information about entering address book profiles for new users.
- If you are going to integrate with a third-party e-mail system, see *Setting Up a Third-Party Mail System*.

## Creating a Diagram of an Organizational Schematic

The first step in reengineering is to get a clear picture of the existing processes used to accomplish the tasks within your organization. To define and name essential and recurring processes, think of each task's beginning and end states.



The following example details a process with starting and ending states for each action in the process:

<b>Process</b>	<b>Starting and Ending States</b>
Budget Preparation	Forecast to allocation
Sales	Prospect to order
Procurement	Requirement to receipt
Service	Inquiry to resolution
Problem	Manifestation to clearance

Diagramming processes in an organizational schematic can help you visualize how they integrate with your system's technology infrastructure and the flow of information within the present structure. The schematic provides a comprehensive definition of the current components that make up these tasks, as well as the information systems used in the organization prior to the application of workflow.

### Identifying Candidate Processes for Workflow

The organizational schematic provides a clear framework for the next step in the process. The organizational schematic identifies appropriate workflow tasks. To do this, analyze your defined business task cycles using well-known performance criteria such as process speed, cost, accuracy, quality, customer satisfaction, and process flexibility. Processes that are not performing well according to these criteria are most likely the ones in greatest need of reengineering. In addition, you should also consider processes that contain many manual steps. After identifying processes that benefit from workflow management solutions, produce a short list of high-priority, high-feasibility projects.

---

After you complete a short list of projects, use one of the following approaches to prioritize these workflow reengineering projects. Consider ranking projects according to:

- Critical Success Factors** For your specific business, rank in order of importance the performance criteria listed above and determine which business processes are most closely connected with those criteria. These processes are directly related to your competitive advantage and success.
- Strategic Imperatives** Prioritize by assessing your company's strategic positioning with competitors, customers, distributors, and suppliers. Considerations such as operational necessity, defensive necessity, and competitive opportunity might be some of the strategic imperatives that are most important to your company.
- Core Competencies** Focus on corporate capabilities that add the most value to your products and services (for example, product development and customer service). By focusing reengineering efforts on these basic capabilities, you'll be strengthening those operations with which your company is most closely identified in the eyes of customers, staff, and the general public.

## Designing Process Prototypes

After you identify the business processes that will benefit most from workflow management, complete the following steps:

### ► To design process prototypes

---

1. Uniquely name each process using a maximum of 10 characters.
2. Assign the process a description using a maximum of 40 characters.
3. Describe the process in detail from beginning to end:
  - Identify where and how a process is called and what the individual activities in the process are, such as whether a business function or subprocess will be called, at what point a message will be sent, or when an application will be launched. Business functions typically update a database with data from the process. Subprocesses are called by other processes and include their own set of activities.
  - Determine all of the relevant data that will be needed throughout the entire process. This step helps you determine which data items to include eventually in the data structures within the process. Data

structures are a fundamental element of any programming language or environment. They are used to encapsulate logically related pieces of data into a single package. This package, or group of data items, is then used to pass information back and forth between different objects, such as forms, business functions, and reports.

- Determine which tables will be updated at the outcome of the process.
4. Create a graphical representation of the process, including the activities and activity conditions that affect it. Activity conditions are user-defined rules that determine which activity executes, as well as what happens after that activity executes.
  5. List the activities as they occur in the process.
  6. Identify your primary data and additional data. Primary data contains the data items that make an instance of a process unique. Additional data contains all the data that the process (and any activity within that process) needs to complete the flow.
  7. Define the messages that the process generates.
  8. Organize distribution lists for the messages that your process generates. Distribution lists allow you to group employees into categories for message routing.
  9. Define any activity conditions.
  10. Define recipient rules that can affect the process. Recipient rules determine to whom or to which distribution list a message is sent.

After you have performed these tasks, you can use Workflow to begin creating your processes.



## Workflow Setup

In addition to creating the Workflow process, you might also need to set up message templates. Workflow processes use message templates to present messages that contain specific information or information that is substituted from data items within the process.

If necessary, you can also set up new queues to which Workflow messages are delivered.

You can set up these components either before or during the creation of the Workflow process.

This section describes the following:

- Setting up message templates
- Setting up queues
- Setting up external mail access





## Setting Up Message Templates

---

When you create a message activity (an activity that sends messages to individuals or to distribution lists), you can choose a predefined message template (or text substitution message) that contains the text used as the body of the message. It might also contain values that are substituted with data from the key data and additional data.

You can set up a new message template before you begin creating a Workflow process or set up the template during creation of a message activity.

Use the following naming convention when creating Workflow message templates:

LMxxxxyyy

where LM identifies the message as a Workflow message

xxxx = the system code (use system codes 55 through 59 for customer-specific messages)

yyy = a sequential number

### **To set up a message template**

---

1. From Data Dictionary Design (GH951), choose Workflow Messages (P92002).
2. On Work With Glossary Items, click Add.

The screenshot shows a software window titled "Work Flow Messages - [Glossary Items]". It features a menu bar with "File", "Edit", "Preferences", "Window", and "Help". Below the menu bar is a toolbar with buttons for "OK", "Can...", "Dis...", "Ab...", "Links", "Displ...", and "Internet". The main area has three tabs: "Item Specifications" (active), "Item Glossary", and "Data Structure Template". The "Item Specifications" tab contains the following fields:

- Alias: LM1235
- Glossary Group: Y
- Language: (empty)
- Domestic Language: (empty)
- Workflow Messages: (empty)
- Product Code: 03B (Enhanced Accounts Receivable)
- Description: Credit Limit Has Been Approved
- Error Level: 1 (Error Message)

3. On the Item Specifications tab, complete the following fields:

- Alias
- Glossary Group

Enter Y to identify the message as a Workflow message.

- Language
- Product Code
- Description
- Error Level

If this is an informative message, such as a message notifying a recipient that an employee's salary has been increased, enter 3.

4. Click the Item Glossary tab.

5. Enter the text for the message.

If the message contains values that will be substituted by data items from your key data and additional data, leave a placeholder for them by using an ampersand (&) and the number of the value.

The form shown in the following graphic shows an example of & and the value number.

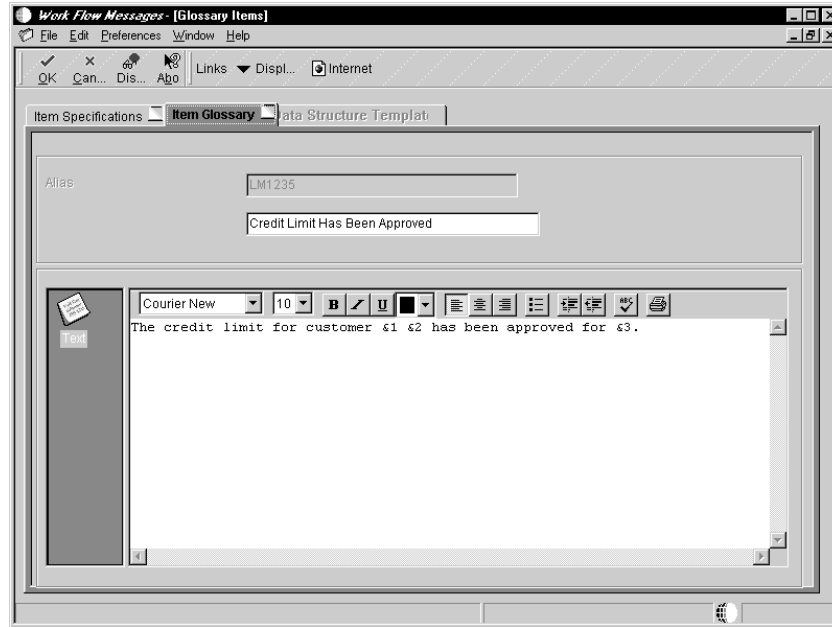

6. Click the Data Structure Template tab.
7. Map the data structure parameters as necessary.

The order of the data is the index of the &x. For example, if the structure contains four members, assign &1 to the first member, &2 to the second, and so on.

8. Click OK when you have finished setting up the message template.

Field	Explanation
Alias	<p>For World, the RPG data name. This data field has been set up as a 10-byte field for future use. Currently, it is restricted to 4 bytes so that, when preceded by a 2-byte table prefix, the RPG data name will not exceed 6 bytes.</p> <p>Within the Data Dictionary, all data items are referenced by this 4-byte data name. As they are used in database tables, a 2-character prefix is added to create unique data names in each table specification (DDS). If you are adding an error message, this field must be left blank. The system assigns the error message number using next numbers. The name appears on a successful add. You should assign error message numbers greater than 5000. Special characters are not allowed as part of the data item name, with the exception of #, @, \$.</p> <p>You can create protected data names by using \$xxx and @xxx, where you define xxx.</p> <p>For OneWorld, a code that identifies and defines a unit of information. It is an 8-character, alphabetical code that does not allow blanks or special characters such as: % &amp; , . +.</p> <p>Create new data items using system codes 55-59.</p> <p>The alias cannot be changed.</p>
Glossary Group	<p>For World, a code which designates a type of data used to select data dictionary terms for printing. See User Defined Codes, system code '98', record type 'GG'.</p> <p>The data item names for error messages are assigned automatically.</p> <p>NOTE: If you need to assign your own error message numbers, use 4 digit numbers greater than '5000'.</p> <p>The data item name for a non-database field (used on a video or report but not in a file – glossary group U) must begin with a #, \$ or @.</p> <p>For help text (glossary group H), the data dictionary “Inquiry/Revision Program” field may be used to specify the name of a follow-on item.</p> <p>To create your own messages for the IBM message file (glossary group J), begin the data item name with your own three characters (e.g., CLT0001).</p> <p>For OneWorld, this field is used to designate the type of data item. It is validated against user defined code table H98/DI.</p> <p>Items in glossary group D or S can be included in database tables. Items in other glossary groups (for example, error messages) cannot be added to a table.</p>

<b>Field</b>	<b>Explanation</b>
Language	<p>A user defined code (01/LP) that specifies a language to use in forms and printed reports.</p> <p>Before specifying a language, a language code must exist at either the system level or in your user preferences.</p>
Product Code	<p>A user defined code (98/SY) that identifies a J.D. Edwards system.</p>
Description	<p>Describes data items. Enter text in upper and lower case. The system uses this field to search for similar data items. To enter an alpha description, follow these conventions:</p> <ul style="list-style-type: none"> <li>Dates – Begin all Date fields with Date</li> <li>Amounts – Begin all Amount fields with Amount</li> <li>Units – Begin all Unit, Quantity, and Volume fields with Units</li> <li>Name – Begin all 30-byte description fields with Name</li> <li>Prompt – Begin any Y/N prompting field with Prompt</li> <li>Address Number – Begin all address numbers (employee, customer, owner) with Address Number</li> </ul>
Error Level	<p>This field indicates the severity of the error message and to denote warning messages.</p>

**See Also**

- *Creating Text Substitution Error Messages* in the *OneWorld Development Tools* guide



## Setting Up Queues

---

Queues categorize messages within the system and organize them in the Employee Work Center. For example, messages can be categorized into queues for priority mail, Internet messages, or submitted jobs. Through a queue, users can approve or reject certain activities in the process flow. You set up a queue in the same way as you set up any user defined code (UDC).

Workflow includes several predefined queues, but you might want to set up a custom queue for messages generated by processes that you create. For example, you might want to set up a queue for messages generated by a credit limit approval process. This queue gathers any approval or rejection messages related to credit limits for customers. A user can then open that queue and act on the message contained within it.

You can set up the following types of custom queues for a Workflow process:

- Queues for categorizing and grouping purposes. For example, you can set up a queue to collect messages regarding credit management information.
- Queues with a shortcut to a OneWorld application. This shortcut opens a OneWorld application that is assigned to that queue and related to the function of that queue. For example, you can set up a queue that is linked to the Over Credit Limit Review form (P03B31).

You can attach shortcuts to queues and to messages. See *Working with Messages* in the *OneWorld Foundation* guide for information about attaching shortcuts to messages.

Complete the following tasks:

- Set up a queue
- Add a shortcut to a queue

### ► **To set up a queue**

---

1. From Workflow Management Setup (G0241), choose Workflow User Defined Codes (G02411), and then choose Employee Task Queues.

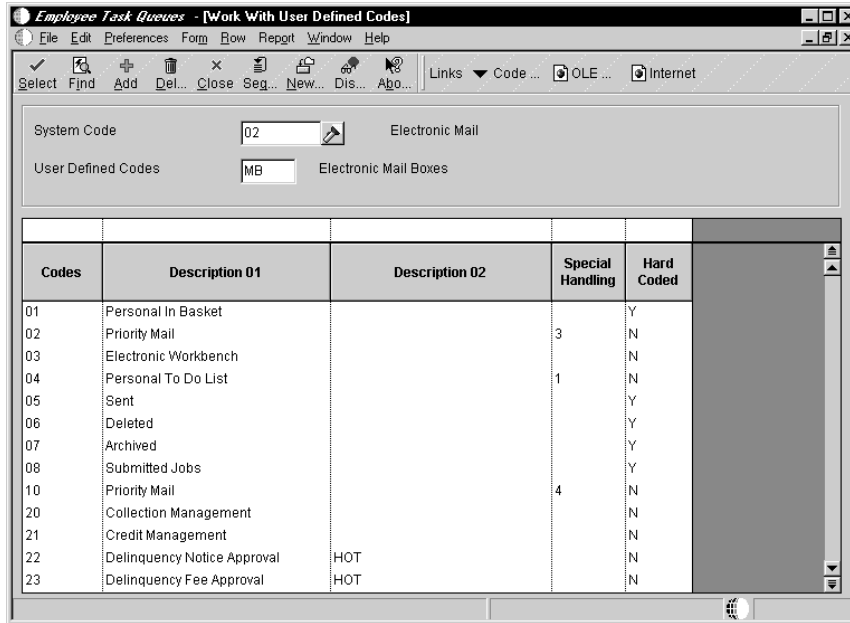

2. On Work With User Defined Codes, click Add.

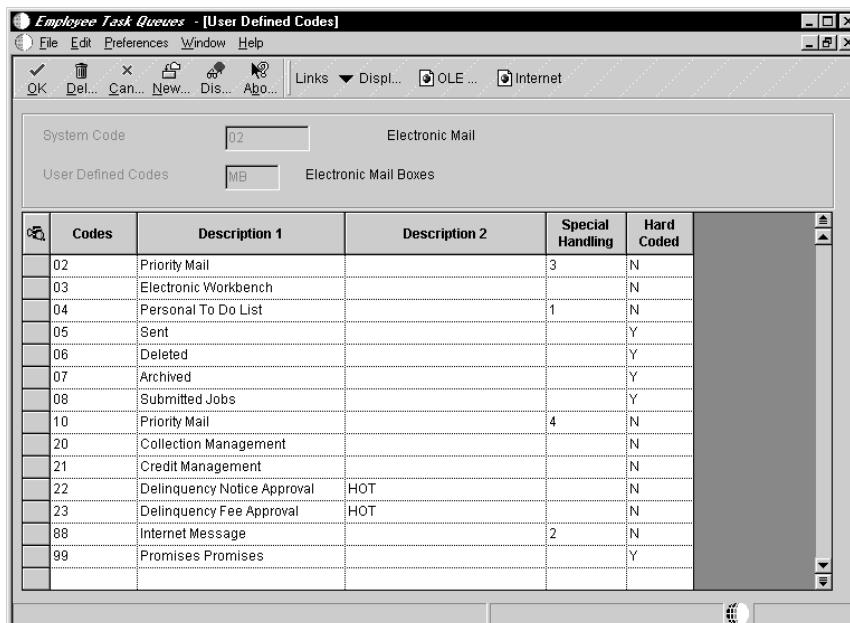

3. On User Defined Codes, complete the following fields in an empty row on the grid and click OK:

- User Defined Code

Enter a unique number for the queue.

- Description

- Description 02

Specify “HOT” for Description 02 if you intend to attach a shortcut to this queue. If you do not plan on attaching a shortcut, this field is optional.

- Special Handling
- Hard Coded

Enter N in this field.

Field	Explanation
Codes	A list of valid codes for a specific user defined code list.
Description 1	A user defined name or remark.
Description 2	Additional text that further describes or clarifies a field in the J.D. Edwards systems.
Special Handling	<p>A code that indicates special processing requirements for certain user defined code values. The value that you enter in this field is unique for each user defined code type.</p> <p>The system uses the special handling code in many ways. For example, special handling codes defined for Language Preference specify whether the language is double-byte or does not have uppercase characters. Programming is required to activate this field.</p>
Hard Coded	<p>A code that indicates whether a user defined code is hard-coded.</p> <p>Valid values are:</p> <p>Y The user defined code is hard-coded</p> <p>N The user defined code is not hard-coded</p> <p>For OneWorld, a check indicates that the user defined code is hard-coded.</p>

**► To add a shortcut to a queue**

You add a shortcut to a queue that provides a link to a OneWorld application if, for example, you want to give a recipient a chance to review information within a OneWorld application whenever he or she opens messages in that particular queue.

1. From Workflow Management Setup (G0241), choose Queue Properties.
2. On Work With Queues, click Add.

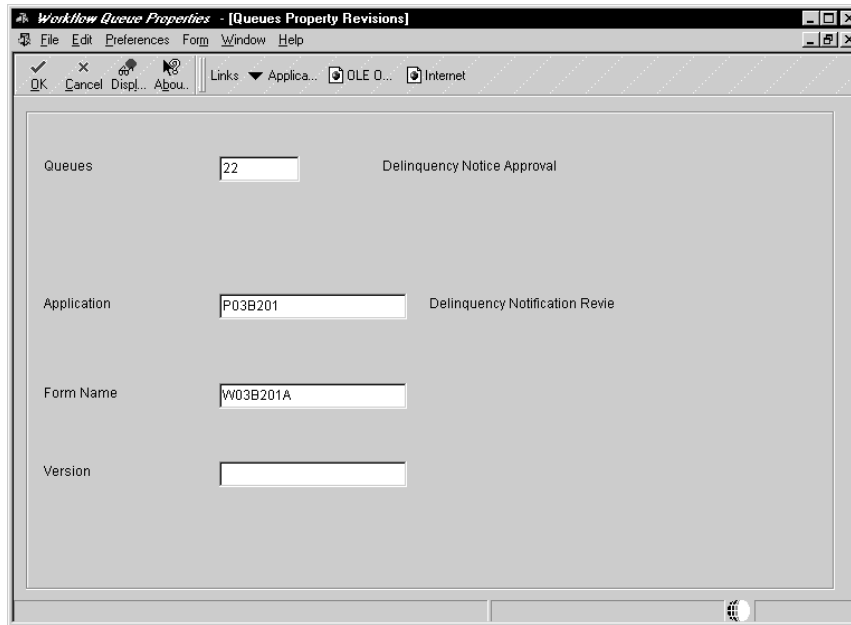

3. On Queues Property Revisions, complete the following fields and click OK:

- Queues

Enter the code number of the queue to which you want to attach a shortcut.

- Application

Enter the program number of the application to which you want to create a shortcut.

- Form Name
- Version

Field	Explanation
Queues	A field that determines the mailbox associated with the queue that should be used on delivery of the message.

Field	Explanation
Application	<p>The OneWorld architecture is object-based. This means that discrete software objects are the building blocks for all applications, and that developers can reuse the objects in multiple applications. Each object is tracked by the Object Librarian. Examples of OneWorld objects include:</p> <ul style="list-style-type: none"> <li>• Batch Applications (such as reports)</li> <li>• Interactive Applications</li> <li>• Business Views</li> <li>• Business Functions</li> <li>• Business Functions Data Structures</li> <li>• Event Rules</li> <li>• Media Object Data Structures</li> </ul>
Form Name	The unique name assigned to a form.
Version	<p>Identifies a specific set of data selection and sequencing settings for the application. Versions may be named using any combination of alpha and numeric characters. Versions that begin with 'XJDE' or 'ZJDE' are set up by J.D. Edwards.</p>

### See Also

- *User Defined Codes* in the *OneWorld Foundation* guide



# Setting Up External Mail Access

---

OneWorld provides an integrated mail system that allows OneWorld users to communicate with each other. OneWorld uses two external mail mechanisms to allow OneWorld users to communicate with others outside of OneWorld:

- Simple Mail Transfer Protocol (SMTP)
- Messaging Application Programming Interface (MAPI)

## Simple Mail Transfer Protocol

Simple Mail Transfer Protocol is a TCP/IP protocol for sending messages from one computer to another on a network. SMTP is used on the Internet to route messages. In OneWorld, the Send Message system function uses SMTP to route messages to external e-mail addresses.

If you choose to enable sending external mail using SMTP, you must add the following lines to the [JDEMAIL] section in the jde.ini file of each OneWorld client:

- Rule1=90|OPT|MAILSERVER=*smtp\_server\_name*

The MAILSERVER setting identifies the name of the SMTP server responsible for sending messages. This setting must be equal to the name of the machine on which the SMTP service is running. This server name is the same as it is listed in the TCP/IP host file on the server.

- Rule2=100|DEFAULT|OWMON=OWMON@jdedwards.com

When the Send Message system function is initiated from the OneWorld Server Administration Workbench, the OWMON parameter is used to determine the From address for the mail message. Set this parameter to an appropriate mail address for your company.

- Rule3=110|DEFAULT|JDE\_SYSTEM=JDE\_System@jdedwards.com

When the Send Message system function is initiated within application or business function event rules, the JDE\_SYSTEM parameter is used to determine the From address for the mail message. Set this parameter to an appropriate mail address for your company.

- Rule4=120|DEFAULT|WORKFLOW\_SYSTEM=Workflow@jdedwards.com

When the Send Message system function is initiated from an activity in a workflow process, the WORKFLOW\_SYSTEM parameter is used to determine the From address for the mail message. Set this parameter to an appropriate mail address as the originator of a workflow message for your company.

- Rule5=130 | OPT | MERGELOCAL=1

For current installations, the MERGELOCAL parameter setting should be equal to 1.

- Rule6=140 | OPT | UPDATELOCAL=0

For current installations, the UPDATELOCAL parameter setting should be equal to 0.

### Benefits of Using an SMTP Server

The following are benefits of using an SMTP server:

- You can separate mail functions along client/server lines, which facilitates the creation of front-end client mail software that is independent of the back-end mail engine. An SMTP server is not dependent on what kind of external mail software is being used in your company.
- You can send messages to anyone with an external mail address by using the Send Message system function. You must pass a valid e-mail address in the recipient field.

## Messaging Application Programming Interface

The Messaging Application Programming Interface(MAPI) is a messaging architecture and client interface that allows client applications to interact with multiple messaging systems. MAPI provides a generic interface that adds basic messaging features to a client application by enabling it to send and read mail from any messaging system that is MAPI-compliant. In OneWorld, the Work Center application includes a MAPI interface that allows it to display, send, and manipulate mail in Outlook, Lotus Notes, or any other MAPI-compliant mail package.

## Setting Up a Third-Party Mail System

To enable the MAPI interface in the Work Center, you must first confirm that the Messaging component of the Windows operating system has been installed on the client workstation. (For Windows NT, this is the Windows Messaging component that is in the Add/Remove Programs dialog accessible from Control Panel. For Windows 95/98, this is the Microsoft Exchange component that is in

Add/Remove Programs dialog accessible from Control Panel.) This component contains the MAPI DLLs and the program that allows you to set up a mail profile to access your mail system. This installation is a required step even if you are not using a Microsoft product for your mail service.

After the Windows Messaging software has been installed, you create a mail profile to identify the mail package with which the Work Center interacts using MAPI. You can create a profile by using the Mail (for Windows NT) or Mail & Fax (for Windows 95/98) icon in the Control Panel. If your company uses a Microsoft product for mail, your profile should be configured for the Microsoft Exchange Server information service. For any other type of mail system (such as Lotus Notes), you must manually configure the information services that are specific to your mail package.

After the mail profile has been created, you must add the following to the [JDEMAIL] section in the jde.ini file of the OneWorld client:

```
mailProfile=mail_profile_name
```

where *mail\_profile\_name* is the name of the profile that you created.

If you do not assign the profile name in the jde.ini file, you are prompted for a profile when you initiate external mail operations in the Work Center.





## Creating Workflow Processes

Use Workflow to translate a business idea into a workflow process. For example, you can create a Workflow process that automatically increases a customer's credit limit based upon an approval routing process. Workflow processes allow you to automate business processes that previously involved a paper trail.

Workflow processes contain activities, which perform an action, such as updating the database, sending a message, invoking an application, or running a report. You link activities together by a sequential flow of events or by some condition that must take place first. You attach key data and additional data to a process to pass information from one activity to the next.

You can add distribution lists to the workflow process. Distribution lists define to whom workflow messages are routed, and can include rules that define when and under what conditions a message should be routed. Furthermore, you can enable escalation processing for a message activity. Escalation processing allows messages to be forwarded to other users if the messages are not answered within in a specified period of time.

This section describes the following:

- Creating a workflow process
- Understanding distribution lists
- Setting up distribution lists
- Adding recipient rules
- Resequencing activities
- Activating a workflow process
- Attaching a process to an application





## Creating a Workflow Process

---

When you create a workflow process you name it, attach key data and additional data, and then add activities. Any process that you create can be used as a subprocess of another process. Subprocesses are useful when you have subsets of activities common to multiple processes or that recur within a process.

For example, you might have a process that increases a customer's credit limit, sends messages to the appropriate parties (such as the customer account representative) that the customer's credit limit has been approved, and then starts a subprocess that prints letters to each customer who received an increase. You attach subprocesses as process activities, but you initially set them up as you do any other process.

To create a workflow process, complete the following tasks:

- Understanding key and additional data
- Naming a workflow process
- Activating a workflow process
- Specifying key data and additional data
- Adding activities to a process
- Adding activity conditions
- Joining activities

## Understanding Key Data and Additional Data

A Workflow process requires two data structures:

- Key data
- Additional data

Key data is the data items that make an instance of a process unique. In other words, key data is the key to the workflow process. You can use multiple data items within key data.

Additional data contains all of the other data that the process (and any activity within that process) needs to complete the process flow. Workflow uses additional data to pass information to activities within the process and to users. The system also uses additional data to track audit information for metrics. The parameters of the key data and additional data are stored in the Process Instance table (F98860). Do not include key data in additional data.

### Workflow Key Data and Additional Data Naming Conventions

Key data and additional data both begin with WF and use the format WFxxxxxyyyA or WFxxxxxyyyB.

WF = indicates a key or additional data selection

xxxx = specifies the system code (use codes 55 through 59 for customer-specific keys and additional data structures)

yyy = represents a sequential number

A = identifies key data

B = identifies additional data

### Example: Key Data and Additional Data

You define both the key data and additional data on the Workflow Revisions form from the Data tab. The following example shows key and additional data for a Workflow process:

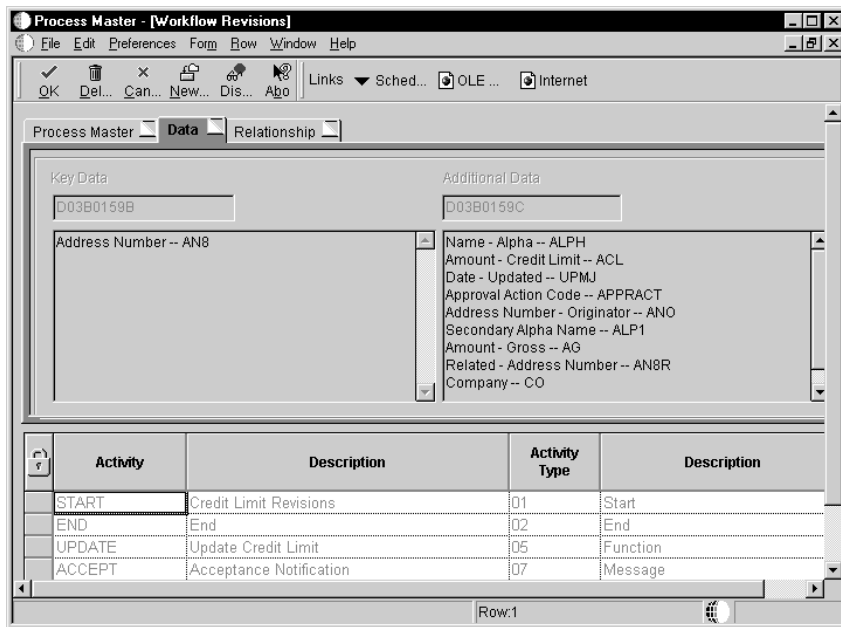

In this example the key data, WF55000A, consists of a single data item, which, in this case, is the customer number for the customer whose credit limit was changed. This data item is used to track the process in the system and, in this example, uniquely identifies an instance of the Credit Limit Changed process.

Additional data, WF55000B, contains the information that an approver of a process might need.

## Naming a Workflow Process

When you add a new Workflow process, the first thing you must do is name it. Name the workflow using up to 10 characters.

Use the format Kxxxxxyyyyy to name a workflow process.

K = designates a workflow process

xxxx = specifies a system code that can be as many as four digits (use codes 55 through 59 for customer-specific processes)

yyyyy = represents a sequential number

You must also provide a description that indicates the purpose of the Workflow process. This description can be as many as 40 characters.



### To name a Workflow process

---

1. From the Workflow Management Setup menu (G0241), choose Process Master.
2. On Work With Processes, click Add.
3. On Workflow Revisions, click the Process Master tab, and then complete the following fields:
  - Process
  - Version
  - Description
  - Product Code
  - Category Code

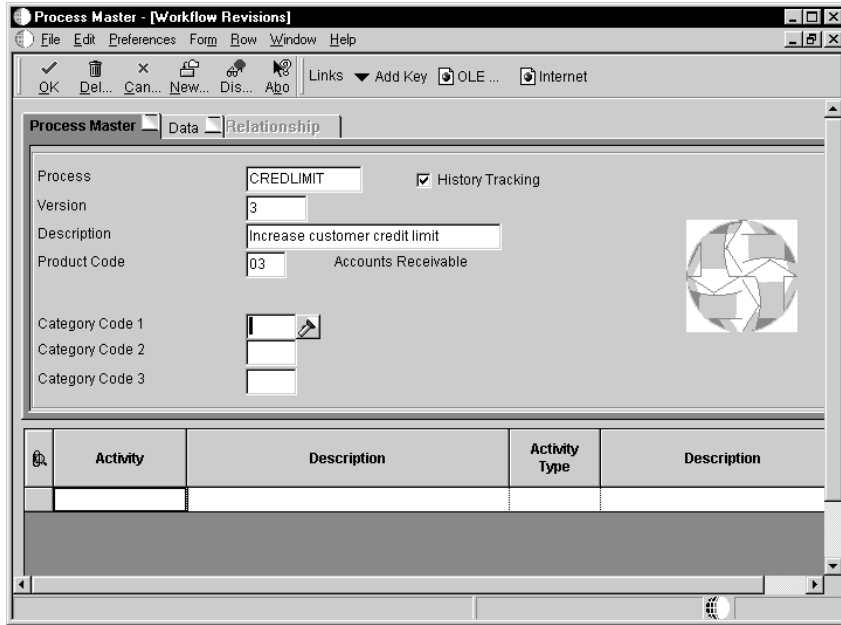

4. If you want to track history for the process, click the History Tracking option.

When a workflow process is started, audit records are saved in the instance tables. If you leave this option off, no audit records will be kept for the process. They are deleted after execution is finished.

Field	Explanation
Process ID	The unique identifier for a process. If no value is entered, a next number is assigned. Once assigned, the value cannot be changed.
Process Version	A number from 1 to 99999 that identifies a unique version of a workflow process.
Workflow Process Description	The description of the workflow process.
Product Code/Reporting	A code that designates the system number for reporting and jargon purposes. See UDC 98/SY.
Process Category Code 1	One of three codes to be used to categorize workflow processes.
History Tracking - Next Process Instance	The next available unique instance for the process. When a workflow process is started, audit records can be written to the instance tables to allow for analysis of the process activity. If you want to track history for this process, choose this option to create instance records.

## Activating a Workflow Process

You can change the status of a workflow process to either inactive or active.

### ► **To activate a Workflow process**

---

1. Find the workflow process you want to modify in the Object Management Workbench.

For more information about how to use the Object Management Workbench, see the *Object Management Workbench* in the *OneWorld Development Tools* guide.

2. Move the workflow process to a project folder.
3. Click the workflow process, and then click the Design button in the center column.
4. On Workflow Design, click Change Workflow Status to toggle between inactive and active.
5. Click Workflow Revisions to access the Workflow Revisions form to make additional changes.

## Specifying Key Data and Additional Data

After you have added and named a new Workflow process, you must specify key and additional data. If key and additional data do not exist for your new workflow, you can define new ones. You can also modify existing key and additional data.

### ► **To specify key data and additional data**

---

1. On Workflow Revisions, click the Data tab.

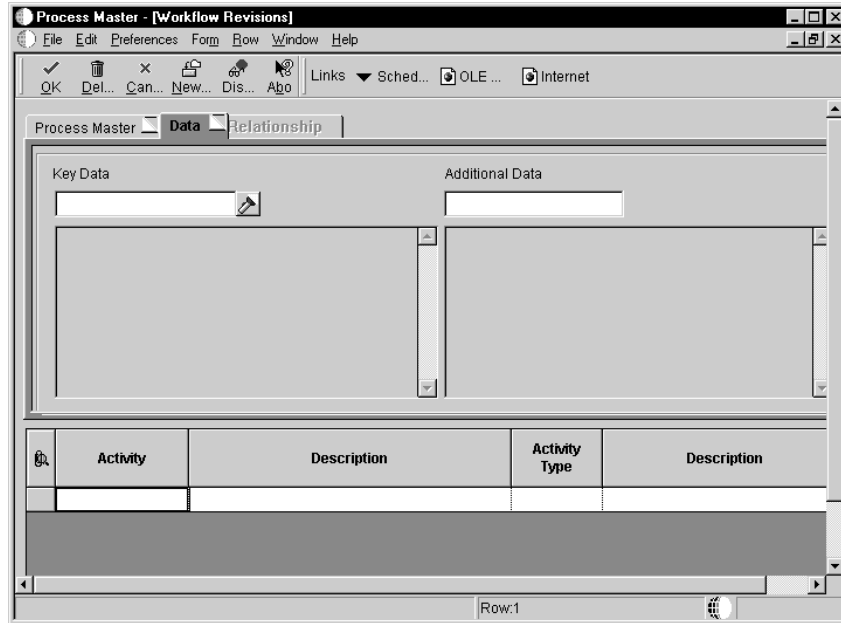

2. To use existing key data and additional data, complete the following fields:
  - Key Data
  - Additional Data
3. To define new key data or additional data, choose Add Key or Add Additional options from the Form menu.

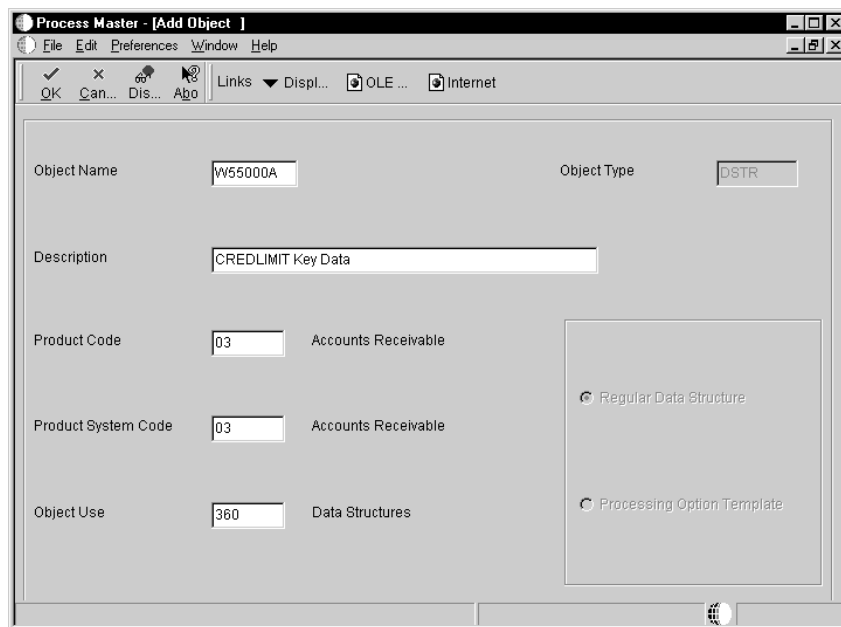

4. On Add Object, complete the following fields:
  - Object Name

The system automatically names the key data or additional data using the appropriate naming convention. You can change this name.

If the object name already exists, then the Key Data and Additional Data fields remain blank, and you must provide another name.

- Description
  - Product Code
  - Product System Code
  - Object Use
5. Click OK.
  6. The system displays the Object Librarian Data Structure Design form. Click the Design Tools tab and then click Data Structure Design.

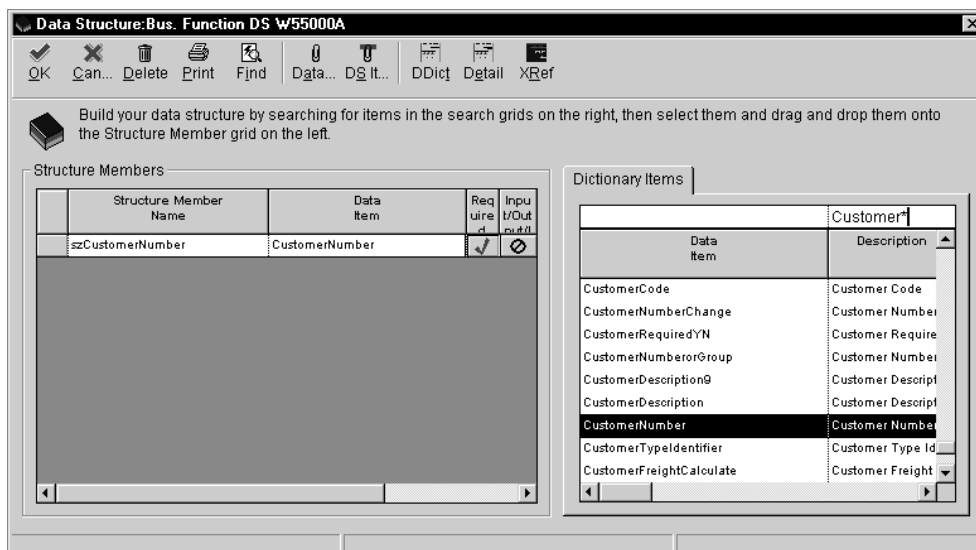

7. On Data Structure, choose the data dictionary items you want to include in the key data or additional data, and drag them to Structure Members on the left.

You can rename structure member items by clicking the data item and typing a new name.

8. When you are finished choosing data items, click OK.

Now you are ready to add activities to the process. Until you attach activities to the process, the Relationship tab appears blank. See *Adding Activities to a Process*.

### Adding Activities to a Process

Workflow activities can include the following actions:

- Sending messages to another participant
- Initiating interactive or batch applications
- Halting a process
- Running an executable program
- Running a subprocess
- Initiating a business function or Named Event Rule (NER)

You use the Workflow Revisions application to add the various types of activities that you want to run when the process starts.

You can define activity conditions that determine when an activity is invoked. After you add activities and activity conditions, you can resequence the activities and change their relationships. See *Resequencing Activities* for more information. You can control the sequence of activities by joining the activities. You can also route messages through recipient conditions.

To add activities to a process, complete any of the following tasks:

- Adding a Function activity
- Adding a Run Executable activity
- Adding a Batch Application activity
- Adding a Recipient Condition activity
- Adding a Message activity
- Adding a Halt Process activity
- Adding an Interactive Application activity
- Adding a Process activity

#### Before You Begin

- Create a process. See *Creating Workflow Processes*

#### Adding a Function Activity

A function activity attaches a business function for special logic processing, including any business functions written in C programming language or NERs written with event rules. A function activity typically updates the database with data from the process. For example, in the Credit Limit Changed process, the Update Credit Limit function activity updates the database if the approval has taken place.

**Before You Begin**

- ❑ Create a business function or NER if one does not exist. See *Business Functions* in the *OneWorld Development Tools* guide.

**▶ To add a Function activity**

1. On Workflow Revisions, click the Data tab, and then complete the following fields:
  - Activity
  - Description

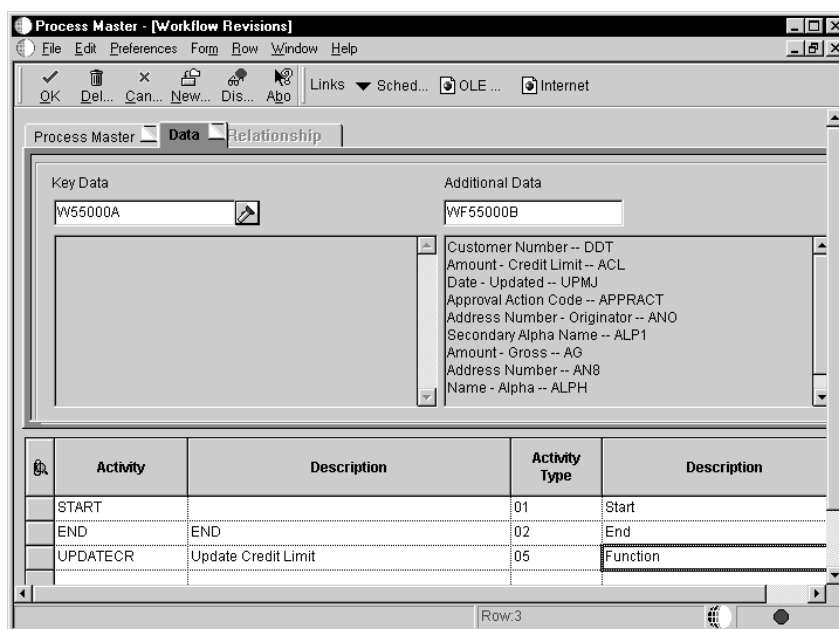

2. Enter 05 in the Activity Type field for a Function activity.
3. Click the row, and then choose Event Rules Definition from the Row menu.

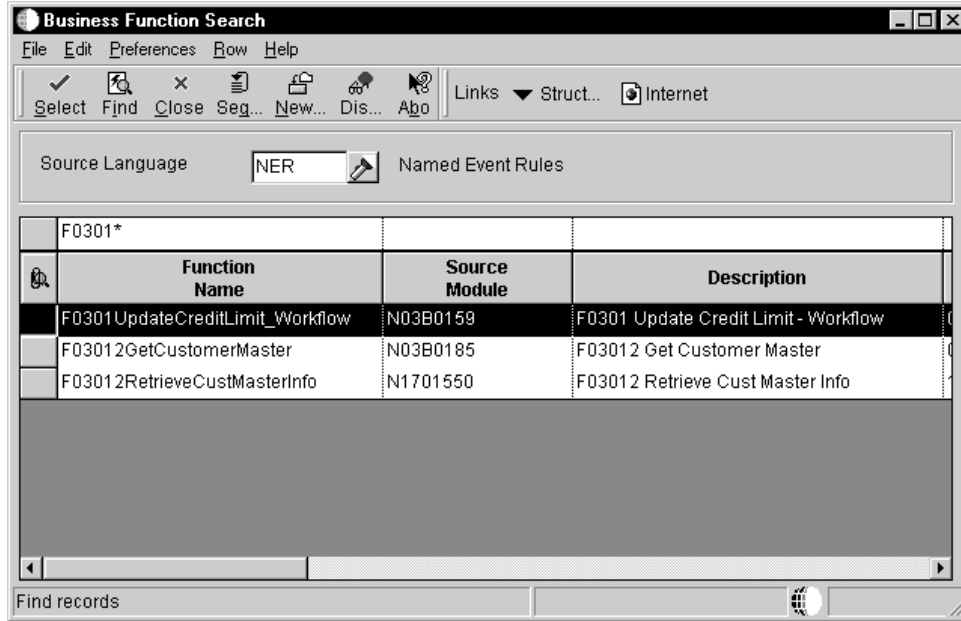

4. On Business Function Search, find and double-click the business function that you want to attach to this activity.
5. On Business Functions, map the parameters that you want to pass to the data item.

For example, map BF mnAddressNumber to mnAddressNumber and map BF mnCurrentCreditLimit to mnCurrentCreditLimit.

The only values available to pass to the business function are those from the key and additional data selections. When you pass these values to the data items in the column on the right hand side of the form, you send the corresponding data items from the workflow key and additional data selections to the function.

The following example shows the data items that are passed into the function so it can update the customer's credit limit to the new credit limit.

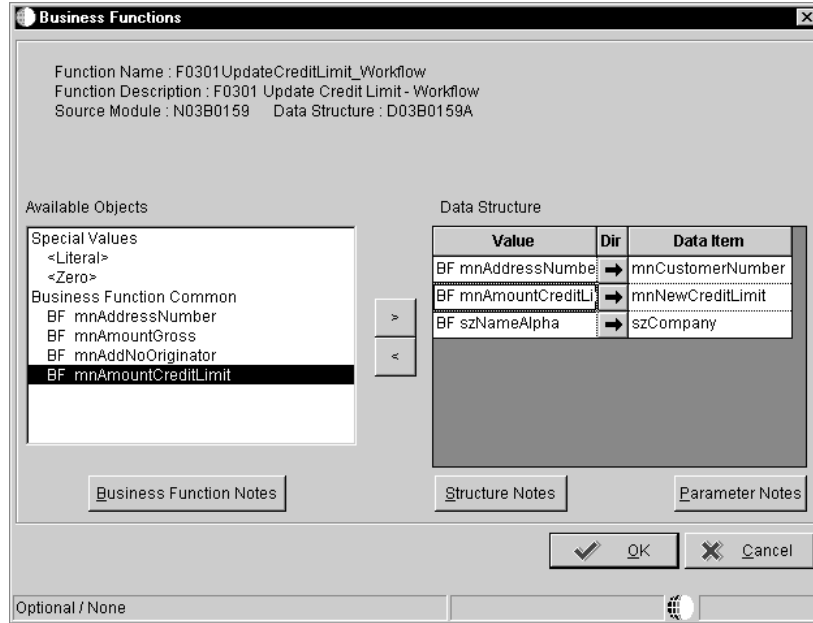

6. Click OK.

### Adding a Run Executable Activity

A Run Executable activity starts a specific application, such as a word processing application or spreadsheet.

► **To add a Run Executable activity**

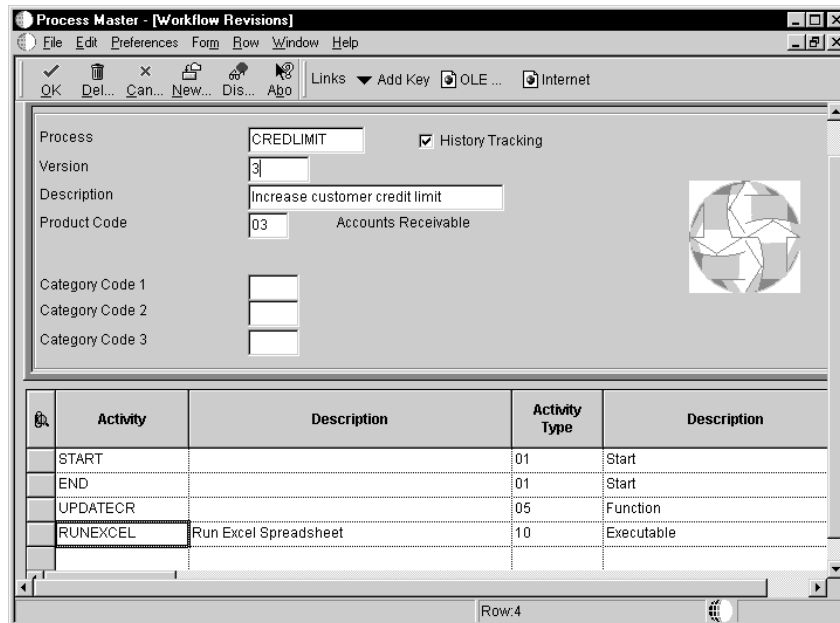

1. On Workflow Revisions, complete the following fields:
  - Activity
  - Description
2. Enter 10 in the Activity Type field for a Run Executable activity.
3. Choose the activity that you added, and then choose Event Rules Definition from the Row menu.

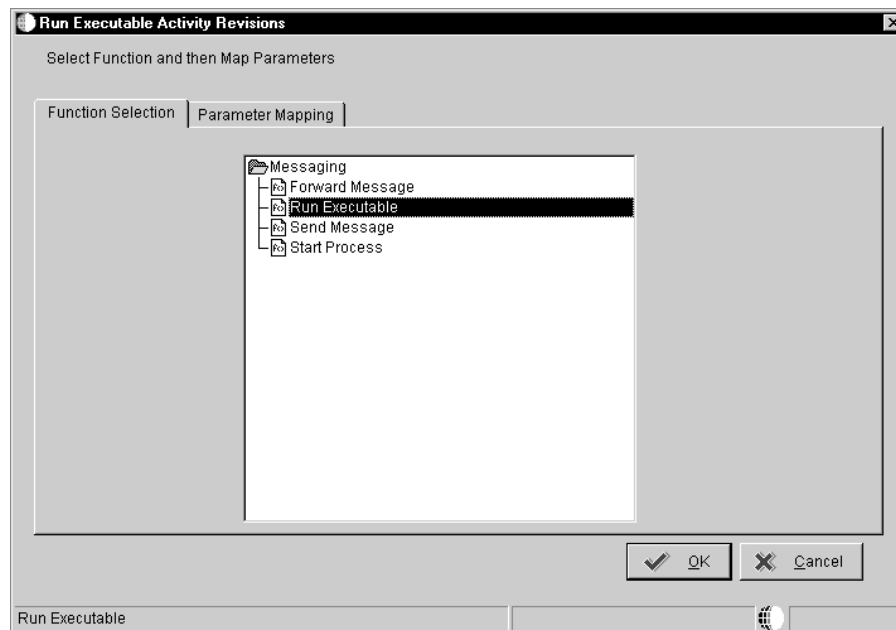

4. On Run Executable Activity Revisions, click the Function Selection tab, double-click the Messaging folder, and then choose Run Executable.
5. Click the Parameter Mapping tab.

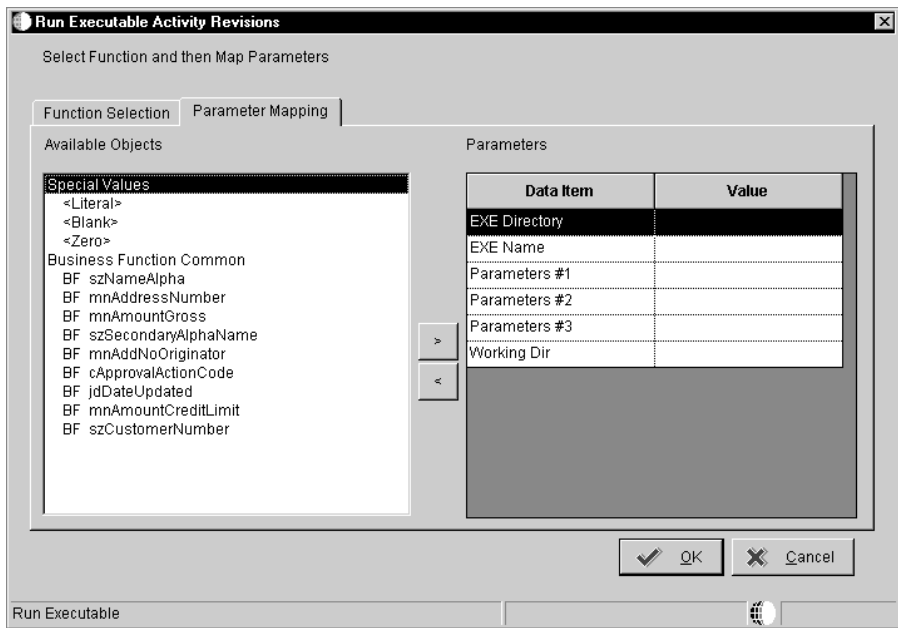

6. Choose the EXE Directory data item.
7. Choose <Literal> from the Available Objects list.
8. On Value, enter the location of the directory to which you want to map (this is the directory where the executable resides), and then click OK.
9. Choose each remaining data item in succession and map the parameters as necessary.
10. When you are finished, click OK.

### Adding a Batch Application Activity

A Batch Application activity starts a OneWorld batch application, such as a report or batch process. For example, you can create an activity that runs the General Ledger Post report or the Leadtime Rollup batch process.

► **To add a Batch Application activity**

The screenshot shows the 'Process Master - Workflow Revisions' window. The form fields are as follows:

Process	CREDLIMIT	<input checked="" type="checkbox"/> History Tracking
Version	3	
Description	Increase customer credit limit	
Product Code	03	Accounts Receivable
Category Code 1		
Category Code 2		
Category Code 3		

  

Activity	Description	Activity Type	Description
START		01	Start
END		01	Start
UPDATECR		05	Function
RUNEXCEL	Run Excel Spreadsheet	10	Executable
RUNCREHIST	Run Payment History Report	03	UBE

1. On Workflow Revisions, in the detail area, complete the following fields:
  - Activity
  - Description
2. Enter 03 in the Activity Type field for a Batch Application activity.
3. Choose the activity that you added, and then choose Event Rules Definition from the Row menu.

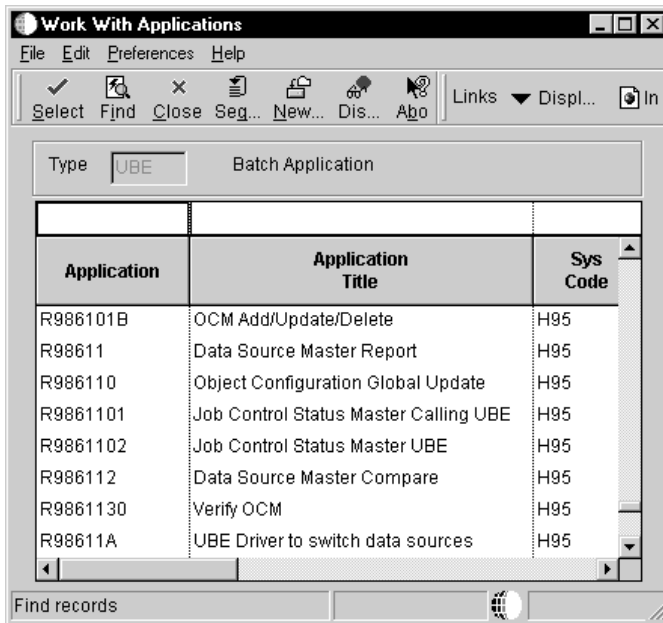

4. On Work With Applications, choose the batch process or the report that you want to attach to the activity and click Select.
5. On Work With Versions, choose the version of the batch process or report you want to use and click Select.

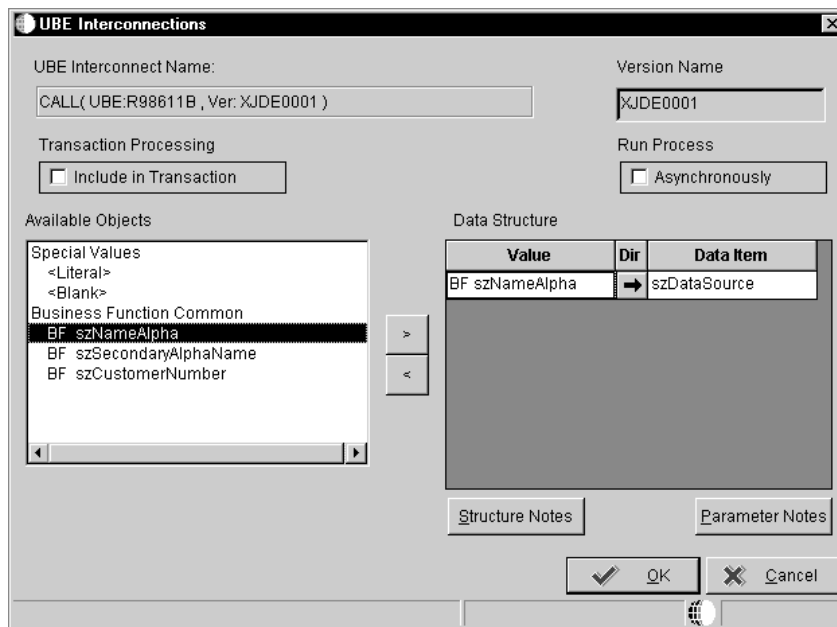

6. On UBE Interconnections, from the Available Objects list, choose the object that you want to pass. Click the > button to add the object to the Data Structure-Value column.

**Note:** You might not need to pass data in your workflow process. Whether or not you pass data in a process or receive data from a process, the Batch Application (UBE) activity must have a report data structure to be able to call it.

7. Indicate the direction of data flow between Value and Data Items by clicking the Directional arrow between the two columns.

If you do not want data to pass between the activity and the batch process, set all Direction values to  $\emptyset$  by clicking on the icon in the Dir field, and then click OK.

**See Also**

- See *Creating a Report Interconnect* in the *OneWorld Development Tools* guide for more information about report interconnections

**Adding a Recipient Condition Activity**

To route messages in a distribution list, create a recipient condition used for escalation and when defining recipient rules. You can add a recipient condition at any point when you are creating a Workflow process.

**► To add a Recipient Condition activity**

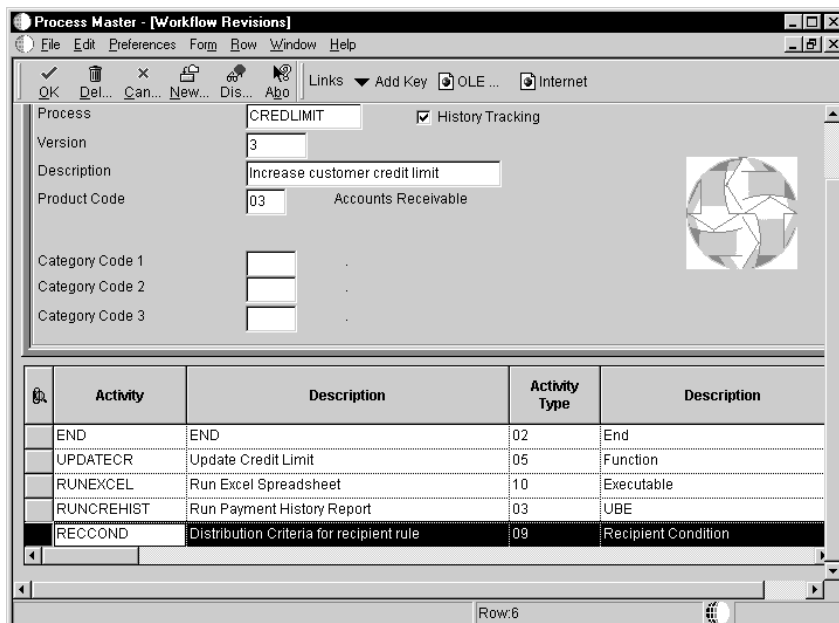

1. On Workflow Revisions, complete the following fields:
  - Activity
  - Description
2. Enter 09 in the Activity Type field for Recipient Condition.
3. Choose the Recipient Condition that you added, and then choose Event Rules Definition from the Row menu.
4. On Criteria Design, enter the logic that you want to add to the Recipient Condition and click Save.

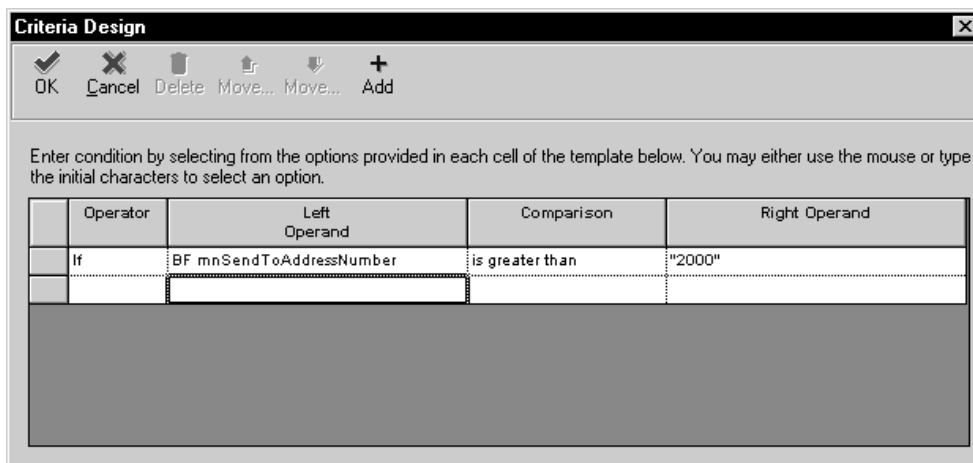

**Note:** When attaching Recipient Conditions to recipient rules, make sure that all values sent to the recipient rule are covered by the Recipient Conditions. Otherwise you may have a value that does not satisfy any conditions, and no message is sent.

**See Also**

- *To add Message activity with escalation*
- *Adding Recipient Rules*

**Adding a Message Activity**

The Message activity sends a message to other users in the system. Messages can contain shortcuts that users click to access other applications, such as the Generic Approval form (P98805). Message activities can also contain a message template. Message templates (or data dictionary Messages) can include substituted values that are populated from the process key and additional data selections as the body of the message. You can enter a new message template through Workflow Messages in the Data Dictionary. See *Setting Up Message Templates* for more information.

To specify to whom a message is sent, and under what conditions it is sent to that recipient, you can attach distribution lists and recipient rules to the Message activity.

To add escalation to a Message activity, you must add escalation rules. Escalation rules are similar to recipient rules because they determine to whom or to which distribution list an escalated message is sent. However, when you add logic to an escalation rule, you can attach a new message to the original message and then define to whom or to which distribution list the escalated message is sent. You must also activate the Escalation Monitor (R98810), which is a batch process that checks for Message activities that contain escalation and forwards any messages that have not been acted upon by a user to the next person in the distribution list. See *Activating the Escalation Monitor*.

To add a recipient rule to a message activity, choose the activity and click Recipient Rules from the Form menu. See *Working with Recipient Rules*.

If you want to attach an existing recipient rule that includes the distribution list and structure type, on Workflow Revisions, choose Recipient Rules from the Row menu. See *Adding Recipient Rules* for information about defining the distribution list and structure type.

Complete the following tasks:

- Add a Message activity
- Add a Message activity with escalation

### Before You Begin

You should consider the following before adding a message:

- Which message template will the message use? If necessary, first create the message template from the Data Dictionary (P92002). See *Setting up Message Templates* for information about how to enter a new message template.
- To which distribution list is the message sent? If necessary, first create the distribution list from Group Revisions (P02150). See *Setting Up Distribution Lists* for information about how to add a single-level or multiple-level distribution list.

### To add a Message activity

---

1. On Workflow Revisions, complete the following fields:
  - Activity
  - Description

2. Enter 07 in the Activity Type field for a Message activity.
3. Choose the activity that you added, and then choose Event Rules Definition from the Row menu.

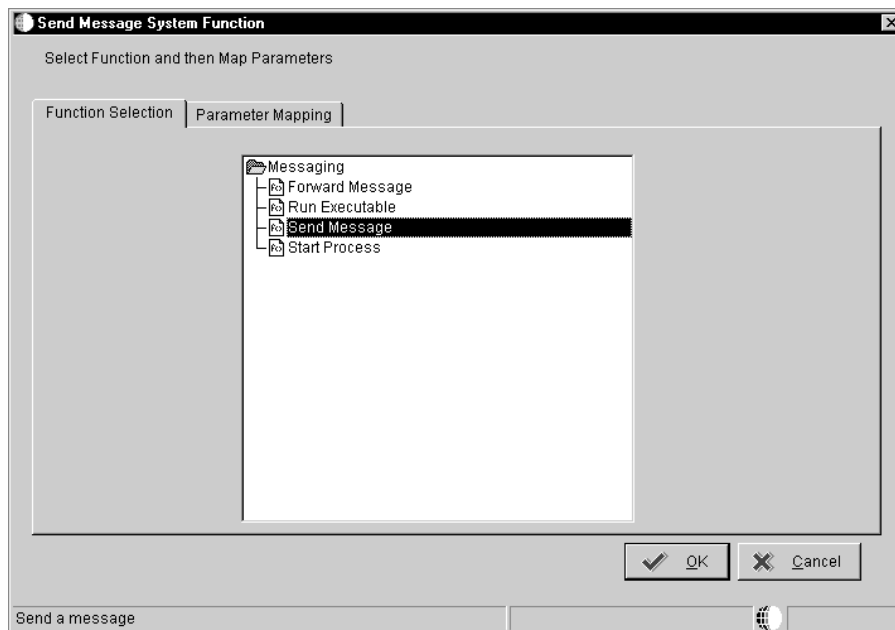

4. On Send Message System Function, double-click the Messaging folder on the Function Selection tab and choose Send Message.
5. Click the Parameter Mapping tab.

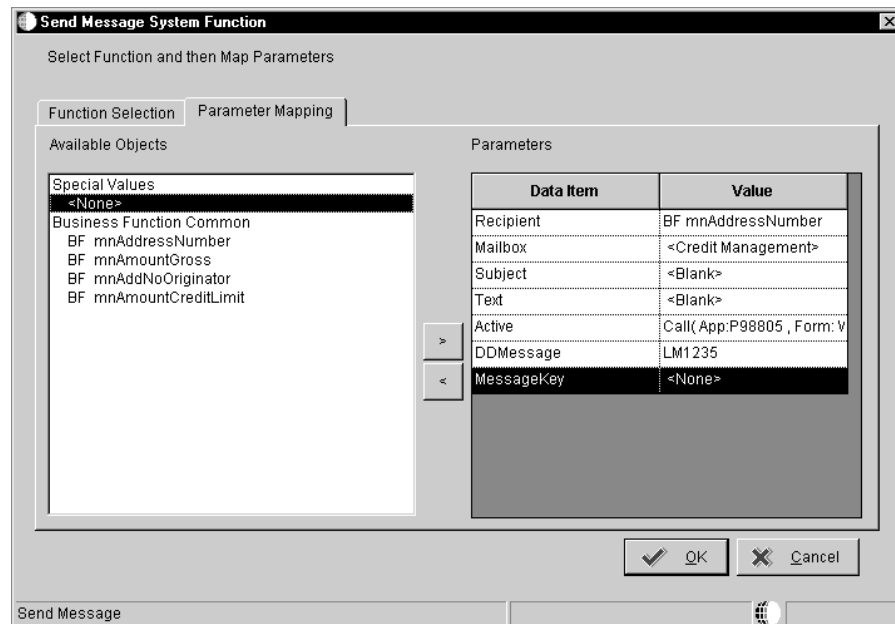

### 6. On Parameter Mapping:

- Indicate to whom the message will be sent by choosing the Recipient data item and mapping it to the corresponding data item that contains the address book number to which the message will be sent.

For example, you might map the recipient data item to BFMnSendToAddress. Or, if you want the message to be sent to a particular person, choose <Literal>, then enter the address book number of that individual on the Single Value form.

If you want the message to be sent to a distribution list, add a Recipient Rule to this Message activity. If you do not add a recipient rule, the message will only be sent to the address book number and not to the members contained within.

You can also enter an external mail address as a literal. Keep in mind, however, that you can only send text messages or messages that contain a template (DD Messages) to an external address.

- Indicate to which mailbox the message will be sent by choosing the Mailbox data item, and then choose the mailbox (or queue) to which you want the message delivered.

For example, you might choose the Credit Management queue for a credit limit approval message.

- If you want to include a subject line for the message, choose the Subject data item and choose the corresponding data item that contains the subject text, if applicable. You can also enter a subject as a literal value. If you do not add a subject line to the message, the subject line will be blank when it appears in the Employee Work Center.

If your message does not require a subject, choose <Blank>. You would most likely choose <Blank> when using a DD Message (a data dictionary message or message template), which would already contain a subject line.

If you want to override the subject line of a DD Message, add a subject data item.

- If you want to add a message that contains static text, choose the Text data item and choose the corresponding data item that contains the text for the body of the message. You can also enter the text as a literal value. If you do not need to use the Text data item, choose <Blank>. Static text does not change.

You can also use the Text data item to add supplemental text to a DD Message if necessary. This text will appear above the DD

Message text when the user opens the message in the Employee Work Center.

- If you want to add a message that contains a shortcut, choose the Active data item and double-click <Define Active Message>.

The system displays Work With Applications.

In the Query by Example row, enter the application that you want to include as a shortcut in the message and click Find.

For example, if you want to use a Generic Message Approval form, enter P98805 and click Find. Double-click the row containing p98805.

On Work With Forms, double-click the row containing the form that you want to use.

For example, you might want to use the Workflow Approval form, which asks the recipient to approve or reject a change, or you might use the Pending Approval form, which notifies the originator that his or her change has been submitted for approval.

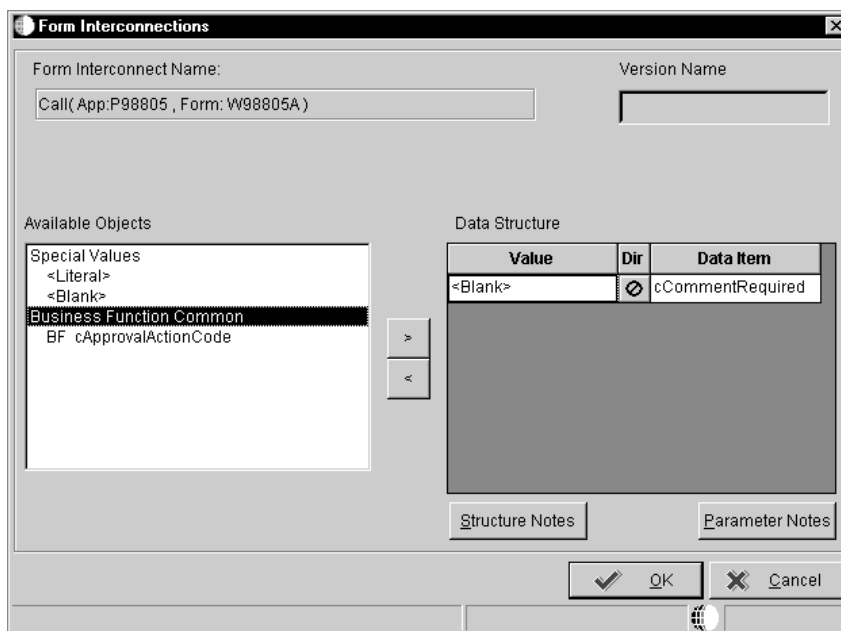

On Form Interconnections, map the data structures to the appropriate available objects and click OK.

See *Understanding Form Interconnections* in the *OneWorld Development Tools* guide for more information about form interconnections.

The system returns to Send Message System Functions.

- If you want to attach a template message, choose the DD Message data item and choose <Define Message> from the available objects. Be aware that attaching a shortcut to a message will suspend the workflow process until the message is acted upon.

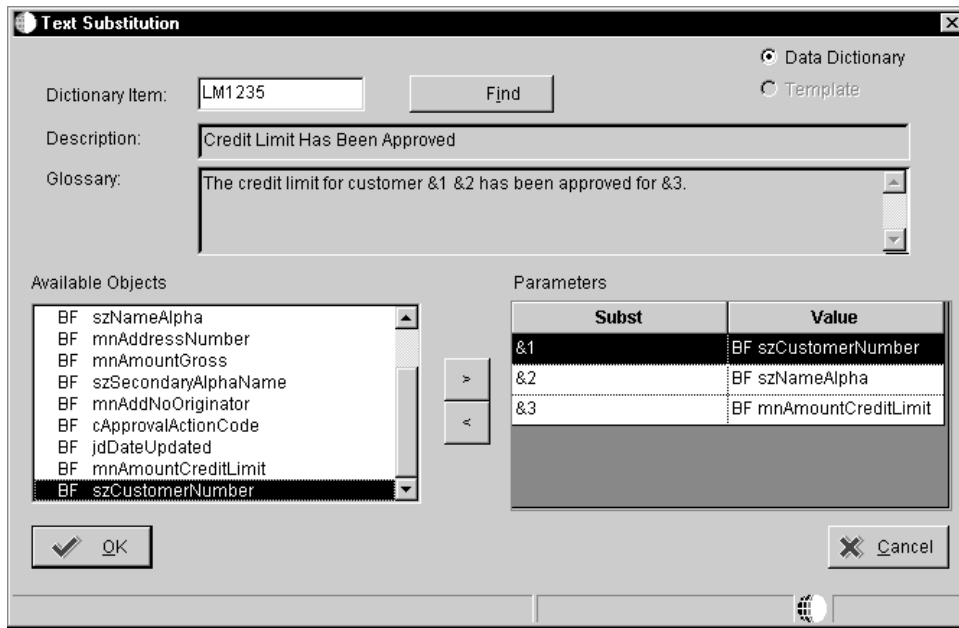

On Text Substitution, enter the name of the message that you want to use in the Dictionary Item field and click Find.

For example, you might enter LM1235 for the Credit Limit Approval message.

From the Available Objects list, choose each data item that contains the value that you want to substitute into the message and click OK.

For example, the parameter &1 (Address Number) would be substituted with the data item BF mnCustomerNumber. Likewise, &2 would be substituted with BF szCustomerName.

- If you want to include a message key, choose the Message Key data item and choose the corresponding data item to which you want the message key returned.

A message key stores the serial number of the message that is sent.

7. After you have finished mapping the parameters for the Message activity, click OK.

► **To add a Message activity with escalation**

1. On Workflow Revisions, in the detail area, complete the following fields:
  - Activity
  - Description
2. Enter 07 in the Activity Type field for a Message activity.
3. Enter Y in the Escalation field.
4. Complete steps 3 through 6 for Adding a Message Activity.
5. After you have finished mapping the parameters for the Message activity and click OK, you are returned to the Workflow Revisions form.
6. When you have completed adding activities on Workflow Revisions, click OK.

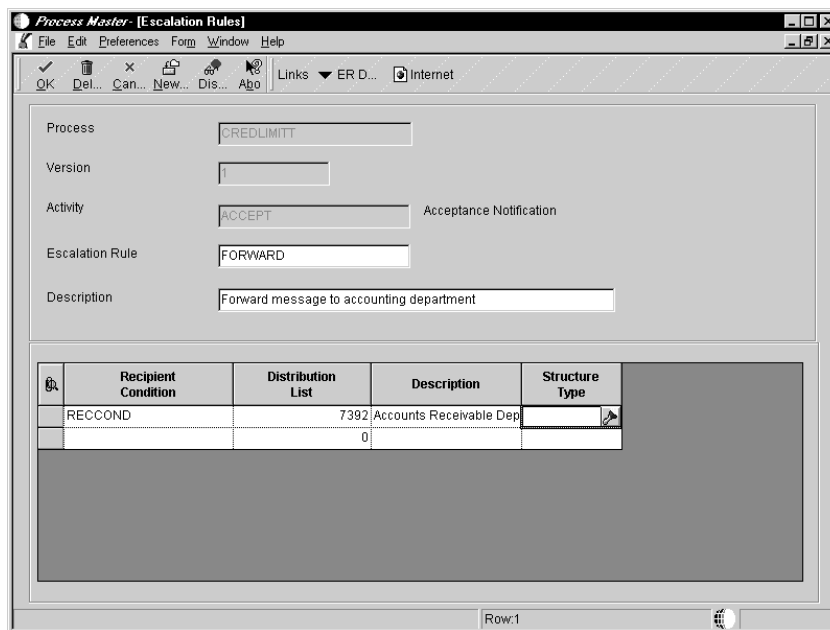

7. On Escalation Rules, complete the following fields and click OK:
  - Escalation Rule
  - Description
  - Recipient Condition

The recipient condition must be added as an activity type 09. See *Adding a Recipient Condition*.

- Distribution List

Enter the distribution list address book number to which the escalated message will be sent.

You must include a distribution list when escalating messages.

- Structure Type

You can use the same combinations of distribution lists and structure types for escalation rules as you do for recipient rules. See *Working with Recipient Rules* for more information about distribution list and structure type combinations.

**Note:** You must add event rule definition to the escalation rule because it defines the message that will be sent to the escalated persons. The attached message can also indicate that the original message is being forwarded to another user because the original recipient did not respond after a certain period of time.

Also, you can edit escalation information after you have added it to a Message activity by clicking the Revise Escalation button in the Row exit bar on Workflow Revisions. Remember that you cannot edit escalation information or anything else within a process if it has been activated or if instances of the process exist.

### Adding a Halt Process Activity

A Halt Process activity stops the process and specifies a period of time that must pass before the process can continue.

For example, suppose you have an employee termination process and an employee is planning to leave the company in the next two weeks. Certain events must happen as soon as the human resources department knows that this employee is leaving the company. The Benefits department must know that this employee should no longer have insurance coverage after a certain date, and the Information Technology department needs to know that computer and phone service for that individual must be terminated when the employee leaves.

In this scenario, the Workflow process is initiated when Workflow messages are sent that indicate that the termination of this employee occurs in two weeks. Then the process is put into a holding state by the Halt Process activity until the actual termination date is reached. Once the termination date is reached, the process resumes, and appropriate action is taken within the system.

When you set up a Halt Process activity, you specify either the hours and minutes or the date and time at which you want the process to resume.

If you add Halt Process activities to your process, you must also run the Escalation Monitor (Check for Expired Activities batch process) on a regular basis. You can run it either manually or through the OneWorld Scheduler application. If you do not run the Escalation Monitor, the process will remain halted. The escalation monitor is what starts the process back up after the date and time has been met.

► **To add a Halt Process activity**

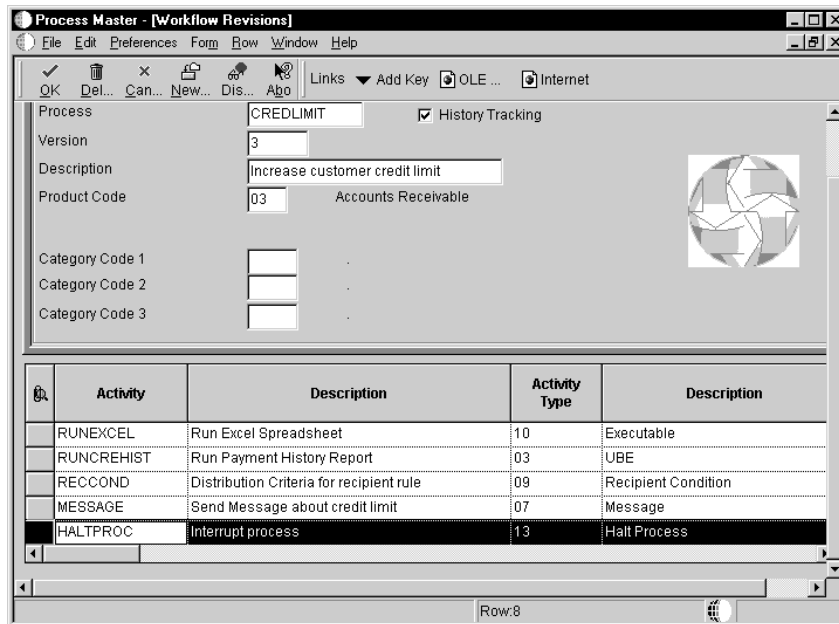

1. On Workflow Revisions, in the detail area, complete the following fields:
  - Activity
  - Description
2. Enter 13 in the Activity Type field for a Halt Process activity.
3. Enter either the Expiration Hours and Expiration Minutes or Expiration Date and Expiration Time at which you want the system to move to the next activity in the process. Then click OK.

For example, you enter 8 hours and 30 minutes in the Expiration Hours and Minutes fields. If the escalation monitor is run to check for expired activities 8 hours and 30 minutes from when that activity within the process is started, the activity is expired. The system expires the halted condition and moves to the next activity.

**Note:** A Halt Process activity has no ER definition.

**See Also**

- *Activating the Escalation Monitor*

**Adding an Interactive Application Activity**

The Interactive Application activity invokes a OneWorld interactive application, for example Work With Journal Entries.

Interactive Application activities cannot be run on the server.

## ► To add an Interactive Application activity

1. On Workflow Revisions, complete the following fields:
  - Activity
  - Description
2. Enter 04 in the Activity Type field for an Application activity.
3. Choose the activity that you added, and then choose Event Rules Definition from the Row menu.

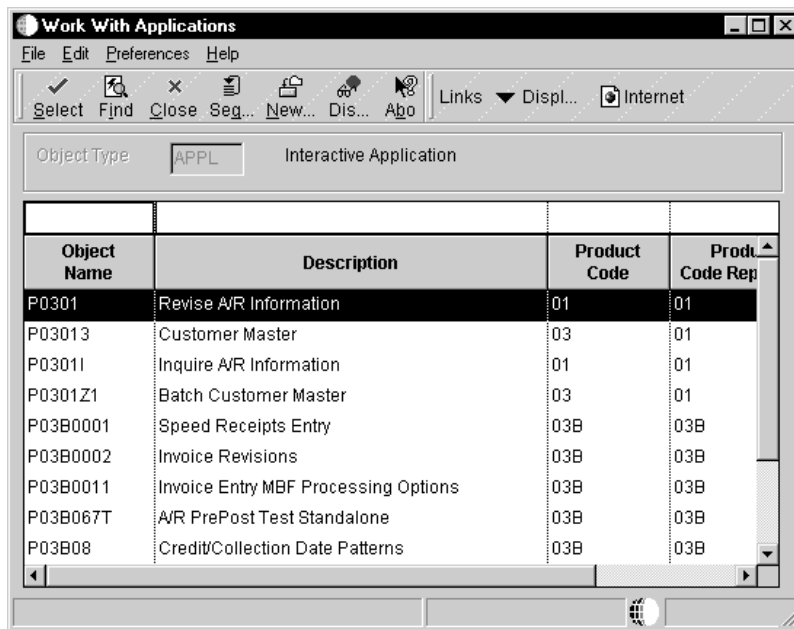

4. On Work With Applications, choose the application that you want the activity to invoke and click Select.

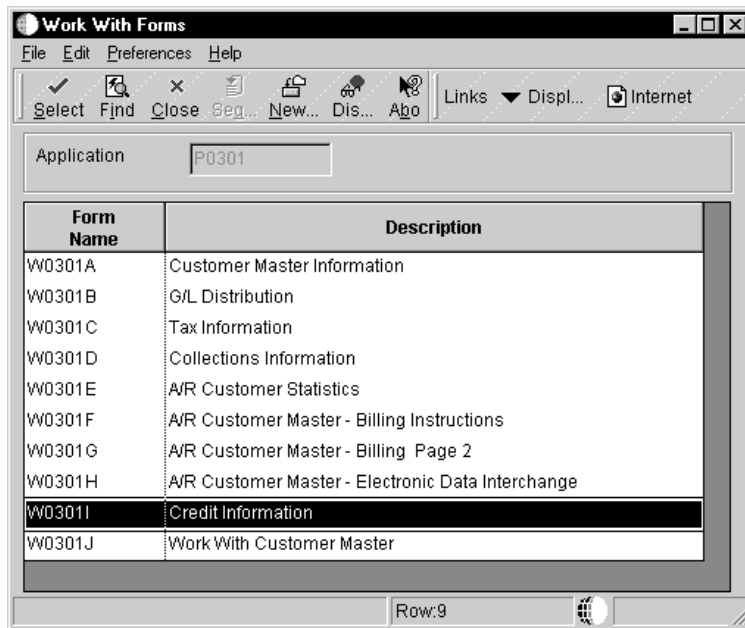

- On Work With Forms, find and choose the form that you want to appear when the application launches and click Select.

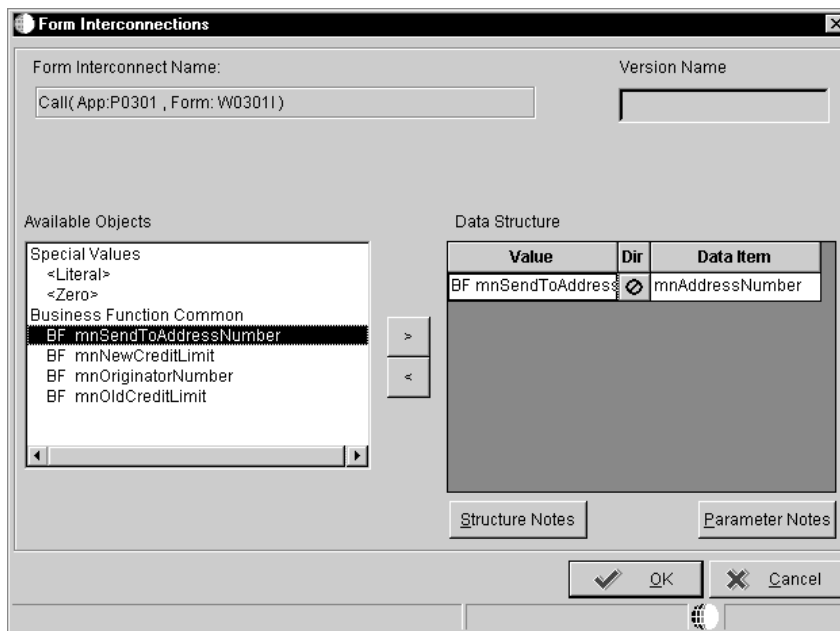

- On Form Interconnections, from the Available Objects list, choose the data item from the primary or attribute data structures that you want to pass to the form that you are calling. Click the > button to add the object to the Data Structure-Value column.
- Indicate the direction of data flow between the Value and Data Item columns by clicking the Directional arrow between the two columns.

8. If you do not want data to pass between forms, set all Directional values to Ø by clicking on the icon in the Dir column.
9. Click OK.

### Adding a Process Activity

A Process activity starts another process, also referred to as a subprocess. A subprocess includes its own set of activities. When you add a Process activity, you are attaching an existing process to the main process.

▶ **To add a Process activity**

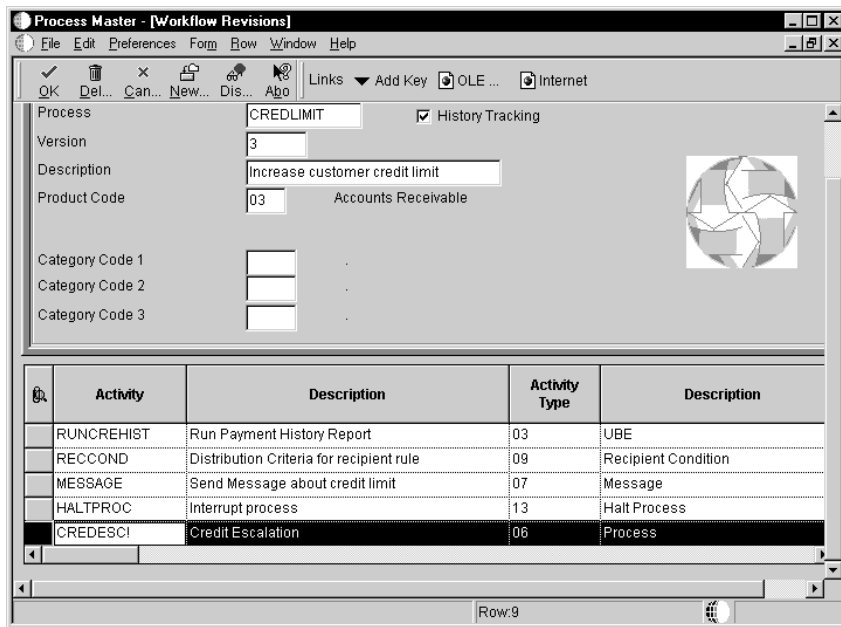

1. On Workflow Revisions, in the detail area, complete the following fields:
  - Activity
  - Description
2. Enter 06 in the Activity Type field for a Process activity.
3. Choose the activity that you added, and then choose Event Rules Definition from the Row menu.

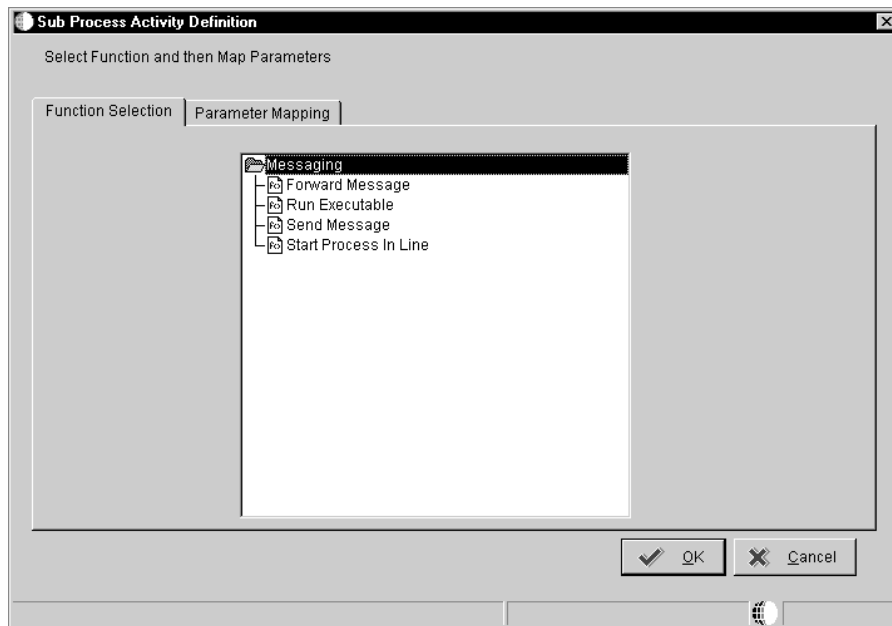

4. On Sub Process Activity Definition, choose Start Process In Line on the Function Selection tab.
5. Click the Parameters Mapping tab.

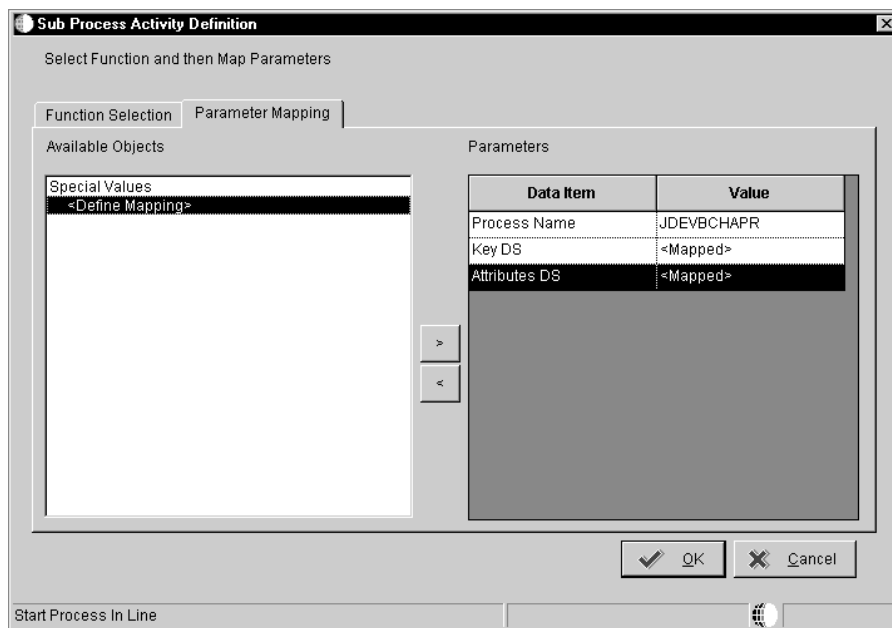

6. Map the available objects to the data item parameters as necessary and click OK.

## Adding Activity Conditions

Activity conditions are user-defined rules that determine which activity runs. For example, an activity condition called “IFAPPROVE” might trigger the system to invoke the activity that updates the database if a user approves a message, and then invokes the activity that sends a message notifying the originator that the message was approved. An activity condition called “IFREJECT” triggers the system to invoke the activity that sends a message notifying the originator that the message was rejected.

You use the Criteria Design form to add logic to an activity condition. The logic that you add determines the condition under which the next activity runs.

If you want to add an existing activity condition to an activity, use the Revise Relationships form. See *Resequencing Activities* for more information.

### ► To add an activity condition

Activity	Description	Activity Type	Description
RECCOND	Distribution Criteria for recipient rule	09	Recipient Condition
MESSAGE	Send Message about credit limit	07	Message
HALTPROC	Interrupt process	13	Halt Process
CREDESC1	Credit Escalation	06	Process
IFACCEPT	If change is accepted	08	Activity Condition

- On Workflow Revisions, complete the following fields:
  - Activity
  - Description
- Enter 08 in the Activity Type field for Activity Condition.
- Choose the activity condition that you added, and then choose Event Rules Definition from the Row menu.

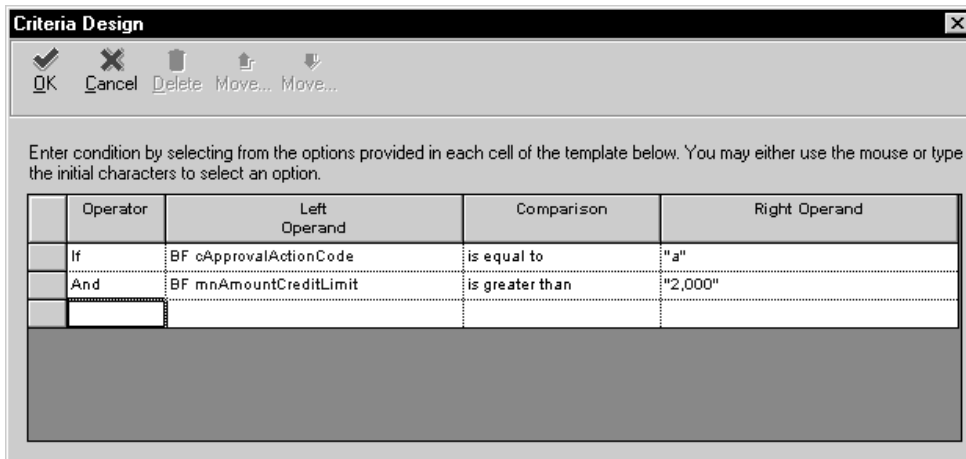

4. On Criteria Design, enter the logic that you want to add and click Save.

## Joining Activities

A join activity is an activity that can be reached by more than one activity through multiple transition paths in the Workflow process. A join activity can be either "and-join", or "or-join". An and-join activity indicates that the activity must wait for all previous activities to complete in order to begin execution. An or-join activity indicates that the first completed previous activity triggers the activity to begin execution. All activities are created as and-join by default-that is, the And-Join column in Workflow Revisions is defaulted to a Y when the activity is created.



# Understanding Distribution Lists

---

You use distribution lists to group employees into categories for message routing purposes. For example, you might set up a distribution list for each department within your company so that you can send messages to each of those groups. Distribution lists are similar to distribution lists in third-party mail programs except that you can further define your distribution lists in OneWorld with:

- Threshold values
- Routing options
- Structure types
- Escalation hours and minutes

You can further define your distribution lists by using groups. When you use groups, you specify at what level within a distribution list that certain people exist. For example, you might organize four members of a distribution list into Group 1, five members into Group 2, and six members into Group 3. When the system sends a message to this distribution list, it first sends the message to Group 1 (the first level in the list), then sends it to Group 2, and sends it to Group 3 last because this group is at the lowest level within the list.

You can arrange distribution lists into a single-level structure, in which there is only one parent (such as the Accounts Receivable group) and the children (managers and employees) are listed directly underneath that parent. You can also arrange distribution lists into a multiple-level structure with several parents, such as the president and all vice presidents within the company, with the employees listed under each of the parents.

## Threshold Values

A threshold value is a static value assigned to an address book number within a structure type. A threshold value is used to determine the floor value of a range of values the process may send. Address book numbers with values falling within the range will be given a Message activity.

When you set up a distribution list, you can enter a threshold value for each employee within the list. The Workflow system uses threshold values to determine to whom an approval should be routed and at what point an approval should be moved to the next level within the distribution list. This value is compared against the associated data item value in the additional data to determine the routing. Threshold values must be ordered from least to greatest.

For example, if you use the associated data item AG (Amount-Gross), and enter a threshold value of 30,000 USD, the system compares the data item against the threshold value. If a customer's credit limit amount has been increased, the system sends a notification message regarding the change to those people whose threshold value is less than or equal to the amount in the Amount-Gross field on the Credit Information form. The data item used for the associated data item must be the same data dictionary item that is in the additional data structure.

You can also use groups in conjunction with threshold values. For example, in Group 1, two members might have threshold values of 10,000 USD, and two other members might have threshold values of 25,000 USD. Group 2 contains two members who have threshold values of 25,000 USD as well. If the system sends a message to the distribution list for a credit limit approval of 20,000 USD, the two members within Group 1 that have a threshold value of 10,000 USD receive the message.

See *Single-Level Distribution List Structure* for an illustration and further explanation about groups and threshold values.

## Routing Options

You can specify conditional routing to control the path of approvals within a distribution list. These routing options are:

### **First Response**

Indicates that if a Workflow message is sent to the members of a group within a distribution list and all members in that group have the same threshold value, then only one of them must respond. After the first response is received by the Workflow system, messages to the other members of that same group are deleted from their queues, and the activity are marked as complete. For example, in a single-level structure, if someone such as Clerk 7101 responds to the message first, then messages are deleted from the other recipient's queues for that group level.

See *Single-Level Distribution List Structure* for an illustration of a single-level distribution list.

First Response is normally used when members of a group have the same authority in the company to grant the same approval.

If you do not choose this option, all members of the list to which the the Workflow message was sent must respond before the activity can be considered complete.

**Higher Level Overrides** Indicates that a member in a higher level group can approve a change through the Process Activity Monitor. All lower level approvals are marked as Bypassed in the monitor and messages to other members are deleted from their queues. If you do not choose this option, then a member in the higher level group cannot approve the change before the lower group.

See Monitoring Process Activity for more information.

For example, if the Vice President (7401) approves a change through the monitor, all the messages that were sent to others within the distribution list below the Vice President in that group level are deleted from their queues. The message is then complete if the Vice President is the last person in the list. If he is not the last person in the list, the message goes to the next highest group member, and so on.

**Authorization Required** Indicates that if a member in the distribution list initiates a Workflow transaction (such as a salary increase himself), it requires authorization from a higher level member. The higher level member receives the message even if the threshold value has not been reached. If you do not choose this option, no higher level person is required to view the message, assuming it is below the threshold value.

For example, if Manager #2 (7202) approves a salary increase for himself, his employee information is not updated with that change unless his supervisor authorizes or approves the Workflow message.

## Escalation Hours and Minutes

Along with threshold values and routing types, you can also add escalation hours and minutes for each employee within a distribution list. Escalation hours and minutes specify the amount of time that the recipient has to respond before a message is escalated to another recipient.

If you categorize members of a distribution list into groups, you must add the same escalation hours and minutes for each member within a group. For example, if one member of Group 1 has 8 escalation hours and 30 escalation minutes assigned to him, then all other members of Group 1 must have 8 escalation hours and 30 escalation minutes assigned to them.

### Structure Types

Structure types can be user-defined and are used to categorize different groups of employees within a distribution list. Structure types further define the type of distribution list you set up. For example, you can set up a structure type of SAL for salary changes, then set up a distribution list in which those employees are all associated with the SAL structure type. Only those employees within that distribution list with the SAL structure type receive messages regarding salary changes.

You can use the predefined structure types of WFS, ORG, or EML to identify the distribution list as a Workflow group, an Organizational group, or e-mail.

#### See Also

- *Adding Recipient Rules* for more information about structure types

### Single-Level Distribution List Structure

In the following example, the single-level distribution list structure is made up of a single level, but all the members within this distribution list are further organized into groups. A message will be sent to everyone within each group in the distribution list, one group at a time, starting with group 1, until the threshold is reached.

In addition, suppose Manager #1 (7201) enters a credit limit increase request for 24,000 USD. Because this value is under the threshold value for Group 3, approval messages will be sent to members of Group 2 because someone must approve them.

## Single-Level Structure

### Structure Type EML



In this single-level distribution list structure, a message with a threshold of 25,000 is first sent to Group 1 (members 7101, 7102, 7103 and 7104), because their threshold values are less than 25,000. If any of these recipients reject the message, the activity completes and the message is not sent to the other groups. However, if all of these members approve the message, it is sent to Managers #1 and Managers #2 in Group 2 (members 7201 and 7202) for their approval because they are in the next highest group on the distribution list. Manager #3 and members in groups 4 and 5 (members 7203, 7301, 7301, 7401, 7402, and 7500) do not receive the message because their threshold values are greater than 25,000.

An exception to this is if the message originator is a member of the distribution list to which the message is sent. In this case, the message is sent to the first group above the originator's group. A message that is sent by 7202 and has a threshold value of 35,000 is first sent to Group 3 (members 7301 and 7302) because these members are in the group above 7201. Only after both 7301 and 7302 accept the message does the message activity complete because the next group (Group 4) does not meet the threshold value. The thresholds for group 4's are all greater than 35,000.

## Multiple-Level Distribution List Structure

You use a multiple-level distribution list structure when you want messages to be sent to the parents within the distribution list first. After the parents in the list receive the message, the system then determines which members beneath that parent should receive the message based on threshold value. If no threshold

values exist for the members beneath a particular parent, the message is sent to all members beneath that parent.

**Note:** Do not include an individual in more than one multiple-level list of the same structure type. This inclusion can result in circular or ambiguous hierarchies that Workflow is unable to reconcile. You must be in the distribution list when using multiple-level distribution list structures.

In the following example, each member of the distribution list has one direct parent. In a multiple-level distribution list structure such as this, the message originator must be a member of the distribution list to which the message is sent. In this case, the message is sent first to the originator's parent (7500) and is then sent to the next parent in turn, provided that the threshold value is met. A message with a threshold value of 45,000 that is sent by 7102 (Clerk #2) is first sent to 7201 (Clerk #1's manager). If the manager approves the message, then 7301, the director, receives the message. After 7301 approves it, the message is sent to 7402. The message activity is then complete because 7402's parent (7500) has a threshold value of 50,000, which is greater than the message's threshold value of 45,000. If any parent within this structure rejects the Message, the message activity completes.

**Multiple-Level Structure**

Structure Type ORG

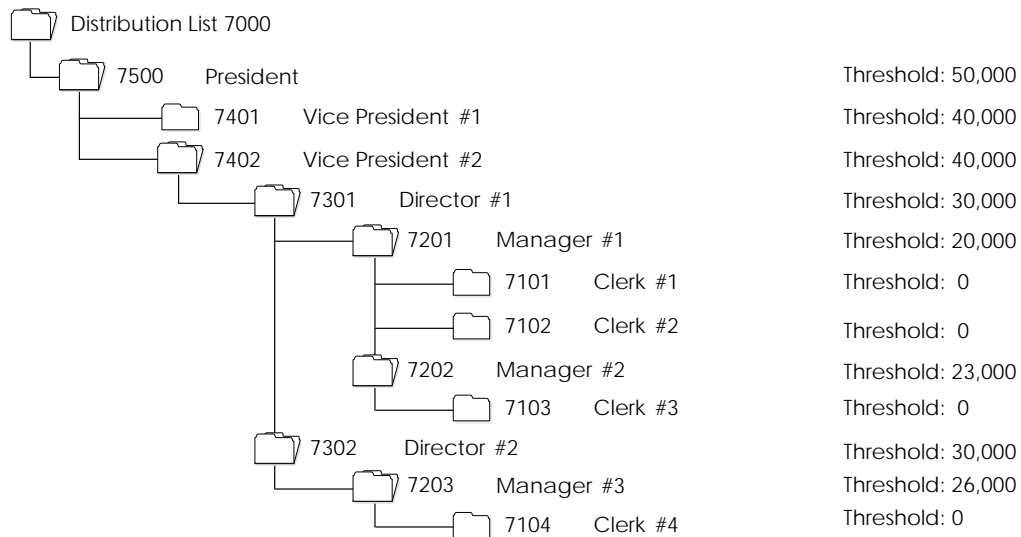

**See Also**

- *Appendix C Distribution List Scenarios*

## Setting Up Distribution Lists

---

You set up distribution lists to group employees into categories for message routing purposes. In Workflow, you use Group Revisions (P02150) to add distribution list parents (such as managers) and then add children (such as employees who work for those managers) to those parents. You can also use Work With Distribution lists to view all the distribution lists of which a child is a member.

You can organize distribution lists into a single level or into multiple levels. For example, you use a multiple-level structure if you want messages to be sent to managers first. You use a single-level structure if you want to categorize members of a distribution list into groups. The way that you group the members of the list determines who should receive a Workflow message first. In other words, members of Group 1 receive messages first, followed by Group 2, Group 3, and so on.

### Distribution List Guidelines

Depending on how you set up distribution lists and threshold values, situations might arise where an action message is not sent to any member of a distribution list. In these cases, the application developer, workflow process designer, or both individuals should take steps to ensure that a process instance completes successfully. Specifically, developers must guarantee that they code for the possibility that when an action message is not sent, the approval code field in the attribute data structure has not been updated. The following two options should allow the process to complete successfully even when no action messages are sent:

- Make sure all additional data structure variables used to store action message results (the approve or reject response) are initialized with an appropriate default value. For example, use 'A' for automatic approval and 'R' for automatic rejection.
- Make sure any conditional rule that evaluates action message response variables after the action message activity considers values other than 'A' or 'R'. For example, if the approval code variable is not initialized, the field may have a blank value ( ' ') by default.

Do not include an individual in more than one multiple-level list of the same structure type. A user cannot be in the same structure type for more than one parent number.

Threshold values assigned to members of a group must be higher than the threshold values assigned to members of the next lower group. For example, the members of Group 2 must have higher threshold values than the highest threshold value in Group 1.

To work with distribution lists, complete one or more of the following tasks:

- Add a single-level distribution list
- Add a multiple-level distribution list
- View the distribution lists of which a child is a member

### Before You Begin

- Make sure that all members that you want to include in the distribution list have been entered into the address book. You must also set up the distribution list's address number in Address Book before you set up the distribution list structure.
- Understand the two structures in which distribution lists can be set up. See *Understanding Distribution Lists* in this guide for more information.

#### **To add a single-level distribution list**

---

1. From Workflow Management Setup (G0241), choose Group Revisions.
2. On Work With Distribution Lists, find the distribution list to which you want to add members and click Add.

Use the Structure Type field to narrow your search.

Group	Address Number	Alpha Name	Threshold Value	Escalation Hours	Escalation Minutes	Rem
1.00	7101	Clerk 1	0.00	4	0	
1.00	7102	Clerk 1	0.00	4	0	
1.00	7103	Clerk 1	0.00	4	0	
1.00	7104	Clerk 1	0.00	4	0	
2.00	7201	Manager 1	20,000.00	24	0	
2.00	7202	Manager 2	23,000.00	24	0	
2.00	7203	Manager 3	26,000.00	24	0	
3.00	7301	Director 1	30,000.00	24	0	
3.00	7302	Director 2	30,000.00	24	0	
4.00	7401	Vice President 1	40,000.00	24	0	
4.00	7402	Vice President 2	40,000.00	24	0	

3. On Address Parent/Child Revisions, complete the following fields:

- Associated Data Item

The Associated Data Item must be the same as what you are comparing it to in the threshold value. Furthermore, it must match a data item in the additional data. For example, if you enter the Associated Data Item AG (Amount-Gross), and enter a threshold value of 30,000 USD, the system compares the data item amount against that threshold value amount. If a customer's credit limit amount has been increased, the system sends a notification message regarding that change to those people whose threshold value is less than or equal to the amount in the Amount-Gross field on the Credit Information form.

**Note:** If a Workflow process stops prior to an active message activity being run, verify that the lowest threshold value in the distribution list is lower than the Associated Data Item value. If the lowest threshold value in the distribution list is not lower than the Associated Data Item value, the process does not have anywhere to send the message because all of the possible recipients are out of the specified threshold range.

- Group

If you want to group members within the distribution list, enter the number of the group in which they reside.

- Address Number
- Threshold Value

4. If this distribution list will be used in conjunction with a message that contains escalation monitoring, complete the following fields:

- Escalation Hours
- Escalation Minutes

Enter the number of hours and minutes that a message can remain unanswered before it is escalated to the next recipient.

**Note:** Escalation hours and minutes must be the same for all members of a group. For example, if member 7101 has 4 escalation hours then 7102, 7103, and 7104 must also have 4 escalation hours because they are all members of Group 1.

5. Enter the beginning and ending effective dates for each member of the distribution list by completing the following fields:

- Begin Eff Date
- End Effective Date

Members within the distribution list are not sent messages unless the current date falls between the beginning and ending effective dates that you specify in these fields.

6. Specify the transitional routing value by choosing one of the following options:

- First Response
- Higher Level Override
- Authorization Required

7. Click OK.

► **To add a multiple-level distribution list**

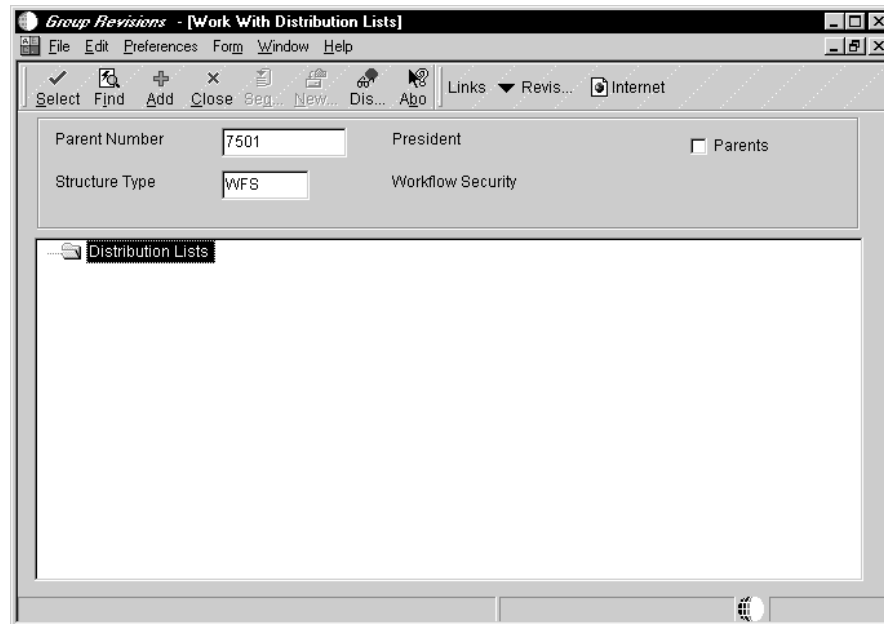

1. On Work With Distribution Lists, find the parent within a distribution list to which you want to add a level.
2. Click Add.

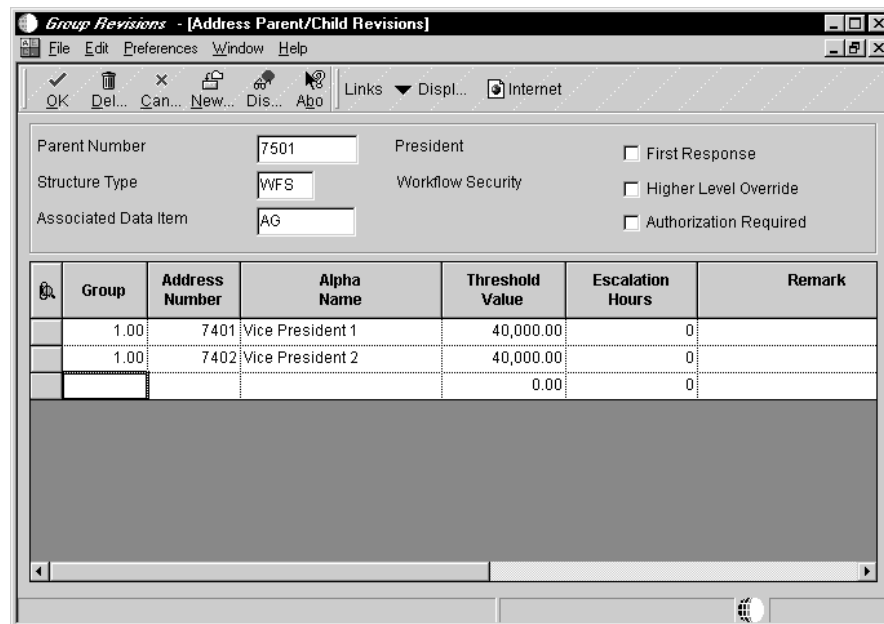

3. On Address Parent/Child Revisions, add members to the parent by following the steps described in adding a single-level distribution list, except that you should enter 1 in the Group field.

You enter 1 in the Group field for every member within a multiple-level distribution list structure.

4. Click OK.
5. To add a level beneath the member when you just added (for example, if you added a president and you want to add vice presidents beneath him), return to Work With Distribution Lists, enter the president's address book number, click Add, and then enter the vice presidents.

Each time that you add another level to the distribution list, you inquire on the address book number under which the next member in the distribution list appears, and then add members to the list.

When finished, your multiple-level distribution list might look something like the following example.

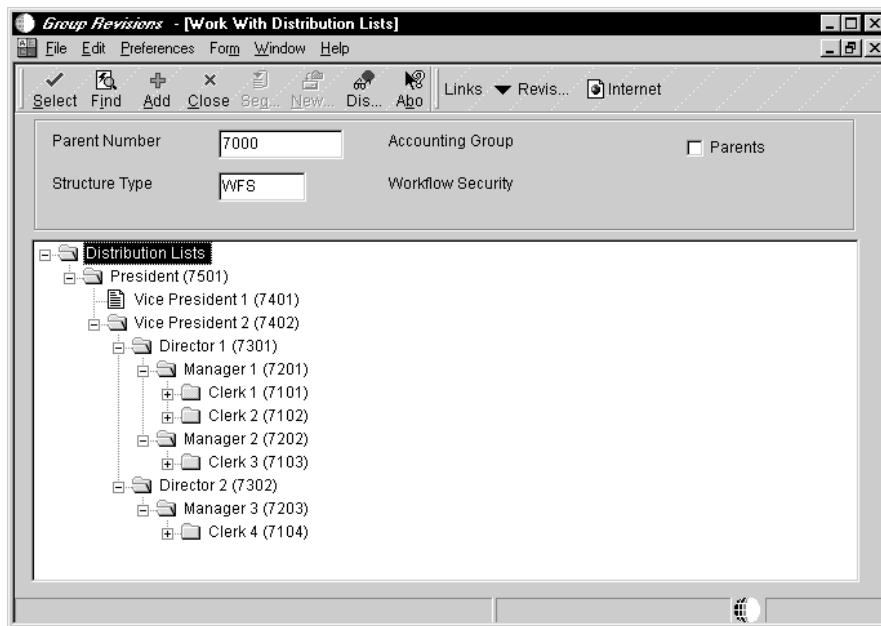

## ► To view the distribution lists of which a child is a member

---

1. On Work With Distribution Lists, complete the following fields:
  - Parent Number  
Enter the address book number of the child for which you want to view all distribution lists.
  - Structure Type

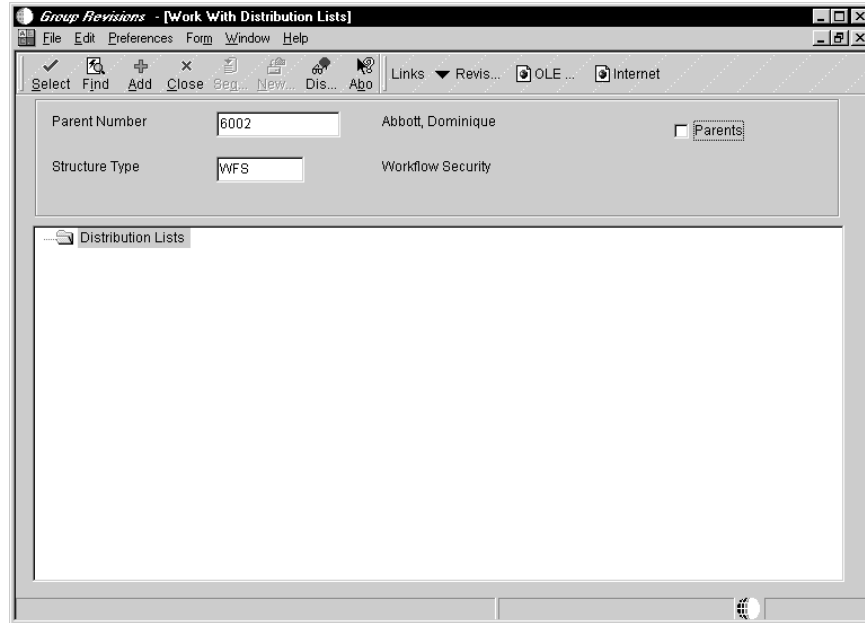

2. Click the following option, then click Find:

- Parents

The system displays the name of each distribution list of which the child is a member. In the following example, Dominique Abbot is a member of the Engineering and Accounts Receivable Department distribution lists.

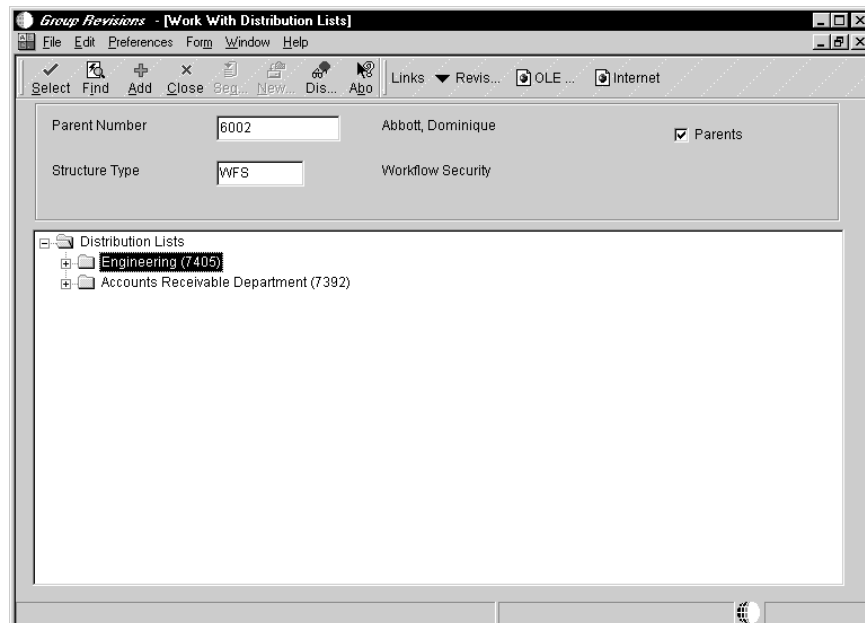

Field	Explanation
Parent Number	<p>The Address Book number of the parent company. The system uses this number to associate a particular address with a parent company or location. For example:</p> <ul style="list-style-type: none"> <li>• Subsidiaries to parent companies</li> <li>• Branches to a home office</li> <li>• Job sites to a general contractor</li> </ul> <p>This address must exist in the Address Book Master table (F0101) for validation purposes.</p> <p>..... <i>Form-specific information</i> .....</p> <p>The Address Book number of the primary level in a hierarchy, or reporting relationship. A parent in one hierarchy can be a child in another hierarchy. A hierarchy can be organized by business unit, employee, or position. For example, you can create a hierarchy that shows the reporting relationships between employees and supervisors.</p>
Structure Type	<p>A user defined code (01/TS) that identifies a type of organizational structure with its own hierarchy in the Address Book system (for example, e-mail).</p> <p>When you create a parent/child relationship for a customer or supplier, the structure type must be blank.</p> <p>..... <i>Form-specific information</i> .....</p> <p>Identifies the type of distribution list, such as WFS for workflow, ORG for group, and EML for e-mail.</p>
Associated Data Item	<p>The data item used to retrieve the formatting information to use on the Threshold Value.</p>
Threshold Value	<p>The value used to determine if certain individuals within the distribution list should be included in the approval of a workflow activity. This can be any numeric field such as an amount, quantity, percentage, and so on.</p>
First Response	<p>If this option is selected, it indicates that if a workflow message is sent to the members of a distribution list, that only one of them must respond. When that first response is received by the workflow system, the other messages to the other members of the group are canceled and the activity is marked as complete.</p> <p>If this option is turned off, all members of the group that the workflow message is sent to must respond before the activity can be considered complete.</p>

Field	Explanation
Higher Level Override	<p>If this option is turned on and a person in a higher level group manually approves a workflow transaction (via a workbench program), then all lower level groups will be marked as bypassed.</p> <p>If this option is turned off, then if a person in a higher level group manually approves the transaction, the action is logged, and all lower level groups are still required to approve the transaction.</p>
Authorization Required	<p>If this option is turned on and a person in the distribution list enters a workflow transaction that goes through the distribution list, the next higher person must be sent the message, even if the threshold has not been reached for the higher person.</p> <p>If this option is turned off, no higher person is required to see the message as long as it is below the threshold.</p>

### See Also

- *Adding Recipient Rules* for information about recipient rules
- *Adding a Message Activity* for information about creating message activities with escalation



## Adding Recipient Rules

---

Recipient rules determine to whom or to which distribution list a message is sent. You add logic to a recipient rule that determines at what point a message is routed to a certain distribution list or recipient. When you create message activities (for example, messages that a recipient can approve or reject), you can add recipient rules to them.

A Recipient Condition contains criteria the system uses in a workflow. You can create a Recipient Condition on Workflow Revisions using activity type 09. After a Recipient Condition is created, you can use it in a recipient rule; however a recipient rule does not require a Recipient Condition. A recipient rule can be defined in a distribution list and structure type.

Adding recipient rules contains the following topics:

- How recipient rules work
- How distribution lists and structure types work
- Adding a recipient rule

### See Also

- *Adding a Recipient Condition*
- *Setting Up Distribution Lists*

## How Recipient Rules Work

Suppose you have an accounting department distribution list and a payroll department distribution list, and you want messages to be sent to one or the other based on a rule. In this case, you might set up a Recipient Condition called IFACCTG that uses the customers address book numbers as the criteria to determine where to send messages. For example, you might add logic to the rule that tells the system that if the customer number is equal to a range of 1 through 3001, then messages regarding those customers should be sent to the accounting department's distribution list.

The following example shows the logic for the IFACCTG recipient condition:

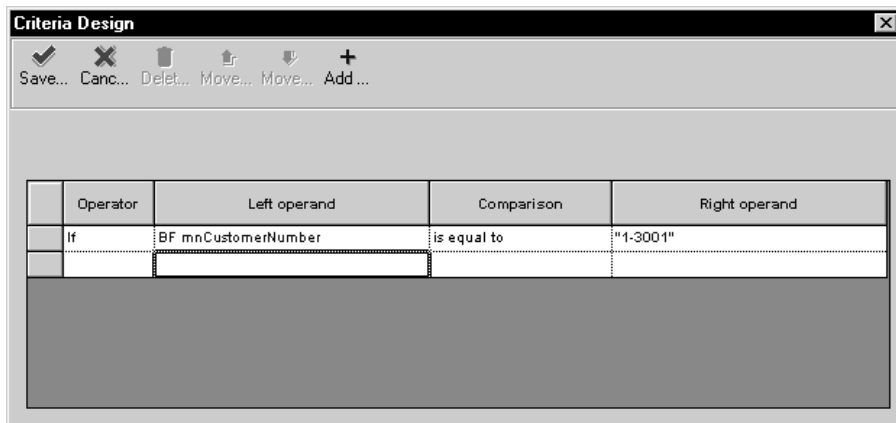

You enter logic to further define a recipient rule. You can also use a combination of distribution list and structure type to determine to whom a message is sent. The following explanations describe when you might want to use a distribution list only, a combination of distribution list and structure type, or structure type only when defining a recipient rule.

## How Distribution Lists and Structure Types Work

The system evaluates the criteria contained in the recipient rule to determine to which distribution list or individual to send a Workflow message. The first criterion that evaluates to true is the distribution list or individual that will be used. If none of the criteria evaluates to true and you have not entered a rule name in the Rule field on Recipient Rules, the structure type is used to determine to whom the message is sent.

For example, if a distribution list (whether it is a distribution list or an individual) and structure type exist for a rule, the system sends the message to the appropriate member in that distribution list. If no distribution list exists, but a structure type exists, the system finds the distribution list with that structure type of which the sender is a member. It then looks to the parent of the sender in that list to determine to whom the message should be sent. If only a distribution list exists for a rule, the message is sent to the address number specified in the Distribution List field.

Three examples of the combinations of distribution lists and structure types that you can use when you set up a recipient rule follow:

### Distribution List Only

When you enter only an address number in the Distribution List field on the Workflow Recipient Rule Revisions form, the system sends the message directly to the address number that you entered.

**Note:** If the address number is the parent number of a distribution list (for example, 7000 - the Accounting Group), the message is sent to only the top level of the distribution list. Therefore, no members of that distribution list receive the message.

The following illustration shows a recipient rule that uses only a distribution list:

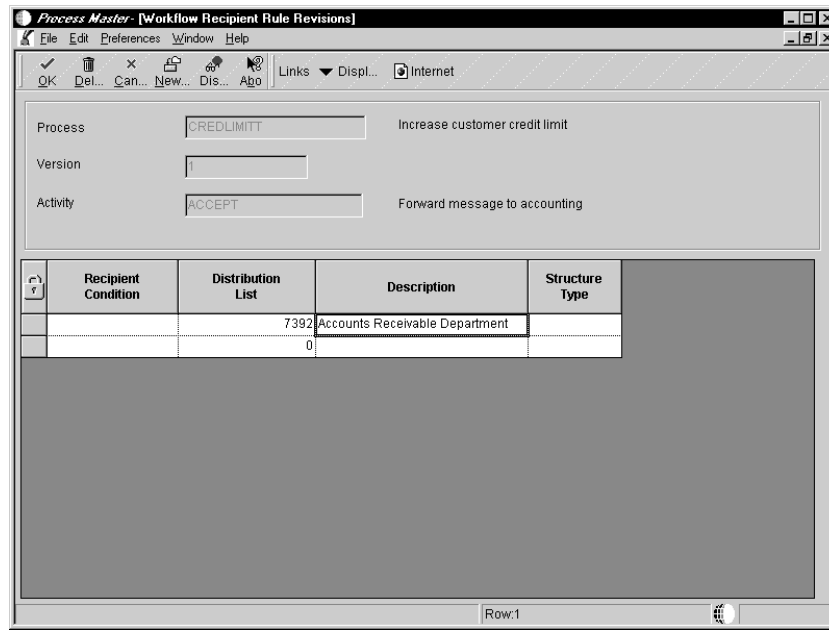

### Structure Type Only

When you enter a structure type but no distribution list, the system finds the address number for the person who originated the initial request, then finds the structure type that you entered in the recipient rule of which the originator is a member. Using the structure type, it finds all the parents to which the originator belongs and then looks at the parents in that structure type to determine to whom the message is sent.

For example, suppose the originator (such as 7101 - Clerk #1) is a member of structure type WFS. The system looks up the structure from Clerk #1 in structure type WFS to find parents with the threshold value that the value associated with the activity falls between to determine to whom the message is sent. In this scenario, the message is sent to 7101's manager, 7201 (Manager #1). If 7201 approves the message, the system then sends it to 7301. If 7301 approves the message, it then sends it to 7402 (Vice President #2), and so on up the distribution list. The message is never sent to a level below 7101, such as 7102 (Clerk #2) or 7202 (Manager #2).

See *Multiple-Level Distribution List Structure* for an illustration and more information about multiple-level distribution lists.

**Note:** If you have set up a multiple-level distribution list, you must enter only the structure type when you set up a recipient rule.

The following illustration shows a recipient rule that uses only the Structure Type:

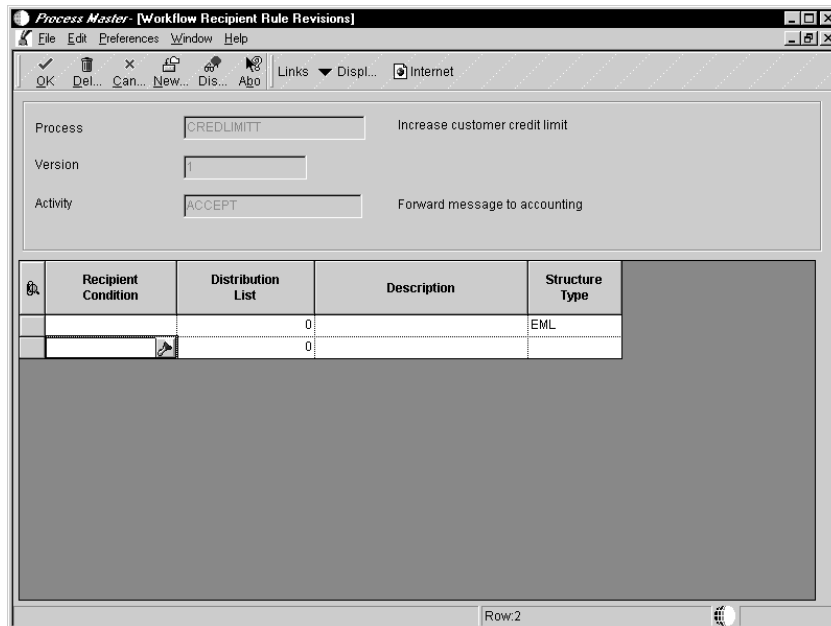

Typically, employees are not attached to more than one structure type. For example, you would not have an employee attached to both distribution list 7000, structure type EML, and distribution list 7384, structure type EML. However, you can have an employee attached to a structure type of ORG who is also attached to the structure type WFS.

### Distribution List and Structure Type

When you include a distribution list and a structure type, the system determines to whom the message is sent by looking down the structure for the individuals with the appropriate threshold value between which the value associated with the activity falls between. The distribution list and structure type combination that you enter must be a valid combination in the Address Book Parent/Child table (F0150).

For example, suppose you enter the distribution list 7000 (Accounting Group) and structure type EML. If an approval message is sent to this group specifying that a customer’s credit limit needs to be raised to 40,000 USD, the system first finds the employees within the Accounting Group distribution list with the structure type EML. Then it finds employees within that structure type with threshold values less than or equal to 40,000 USD and routes the message directly to them for approval.

If you have created a single-level distribution list, you use both a distribution list and structure type for the recipient rule.

## Adding a Recipient Rule

You attach recipient rules to a message activity on the Workflow Revisions form. When you add a recipient rule, you must define it using one or more of the following:

- Recipient condition
- Distribution list
- Structure type

**Note:** If you enter a literal or any other parameter for the recipient when you add a Message activity, you do not have to add a recipient rule. If you add a recipient rule to a Message activity that already contains a parameter for the recipient, the recipient rule overrides the parameter that you entered.

### ► To add a recipient rule

1. On Workflow Revisions, choose the Message activity to which you want to attach a recipient rule.
2. Choose Recipient Rules from the Form menu.

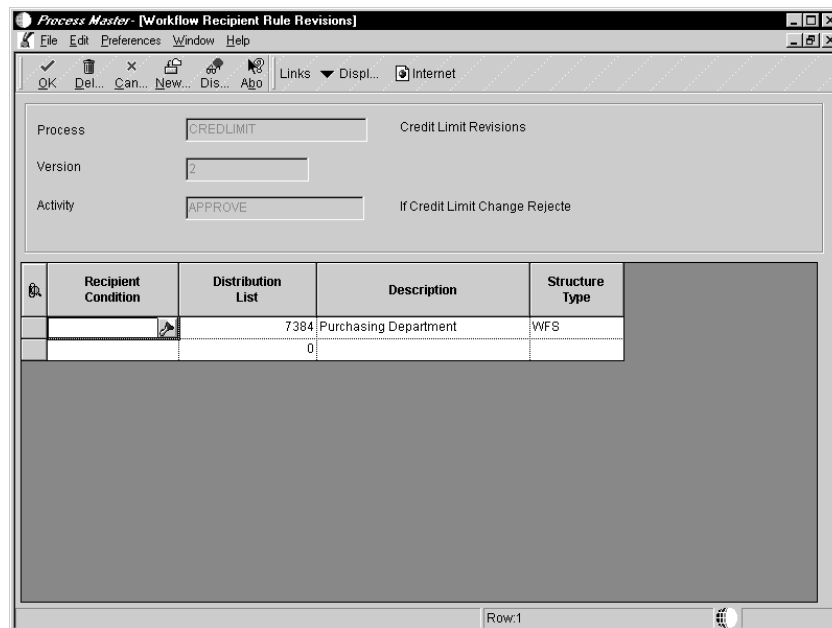

3. On Workflow Recipient Rule Revisions, complete one or more of the following fields and click OK.

- Recipient Condition

You must add a Recipient Condition before you attach a recipient rule that uses Recipient Conditions; however, a recipient rule does not require a Recipient Condition. A recipient rule can use multiple Recipient Conditions. See *Adding a Recipient Condition*.

Enter the name of the Recipient Condition that you want to use. Click the visual assist to view Recipient Conditions.

- Distribution List

Enter the address book number of the distribution list or individual user to whom the message is sent, based on the Recipient Condition.

- Structure Type

# Resequencing Activities

When you add Activities and Activity Conditions to a process, the system automatically sequences and creates relationships between them. However, you might want to resequence the activities and conditions and, in so doing, change the relationships between them.

You can also add activity conditions to activities at this point, as well as access the Scheduler to schedule the Check for Expired Activities batch process. To schedule a job, choose Scheduler from the Form menu on Workflow Revisions.

The following task describes an example of how you might resequence activities for the Credit Limit Approval process.

## ► To resequence activities

1. From Workflow Revisions, click the Relationship tab to view the current activity relationships.

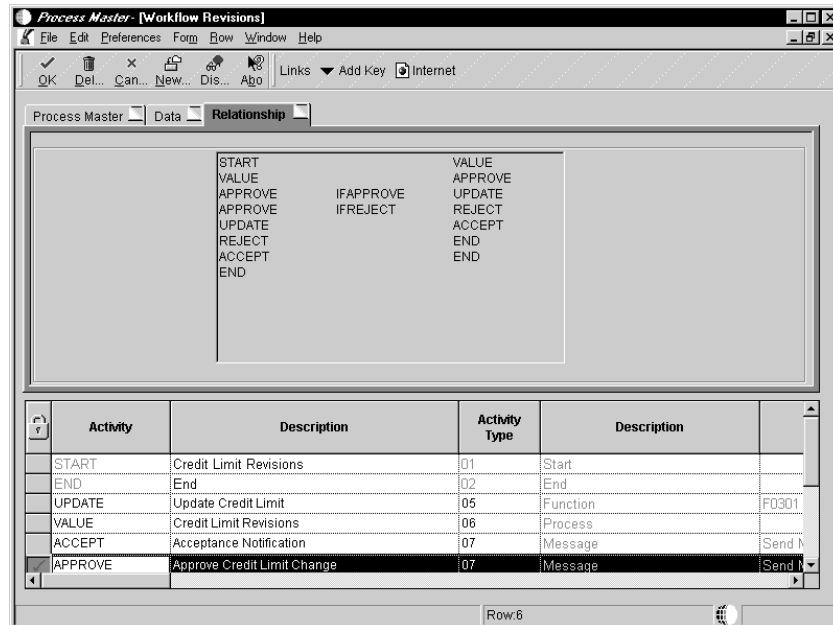

2. Choose Revise Relationship from the Form menu.

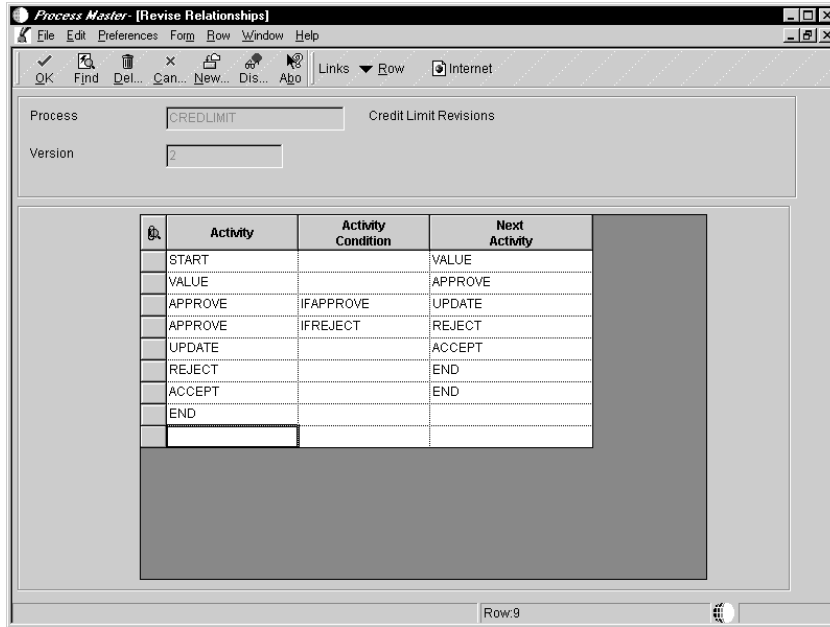

3. On Revise Relationships, sequence the activities in the order in which you want them to execute. For example, the next activity after Start might be Approve.
4. On the next row, in the Activity field, enter the same activity that appears in the Next Activity column in the row above this one. In this example you enter Approve in the Activity field, and then enter any activity conditions that apply to that activity in the Activity Conditions field, such as IFAPPROVE. The IFAPPROVE activity condition tells the system that if a user approves a message for a credit limit increase, the system invokes the next activity.
5. Add the next activity after the IFAPPROVE condition in the Next Activity field, such as UPDATE. The UPDATE activity tells the system to update the database if the message is approved.
6. You can add more than one activity condition to an activity. In this example you can add the IFREJECT activity condition to the Approve activity. The IFREJECT activity condition tells the system that if the request to increase a customer’s credit limit is rejected, the system should invoke an activity other than the UPDATE activity.

In this case, the next activity to be run after the IFREJECT activity condition is REJECT, which sends a message to the originator of the request, notifying him or her that the credit limit increase has been rejected.

7. In the next row, in the Activity field, enter REJECT. In the Next Activity field, add the next activity that is invoked, such as END, which ends the flow of activities.
8. When you are finished resequencing and adding relationships between the activities and activity conditions, click OK.

If a Next Activity does not have a corresponding Activity associated with it, an error message appears. The system will not save the updated information in Advanced Setup until you ensure that there are relationships between all activities in the process.

**Note:** Activity information is stored in the F98810 table and activity relationship information is stored in the F98830 table. If you click OK on Advanced Setup after resequencing the activities and conditions, and an activity is not represented in the F98830 table, the system displays a message indicating that the flow is noncontinuous.

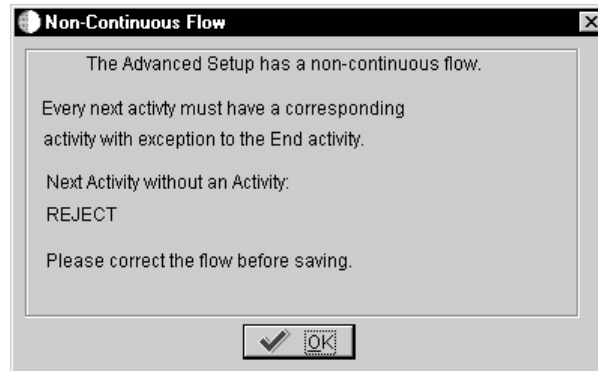

If you do not use an existing activity, the system asks for confirmation that you want to delete that activity from Advanced Setup.

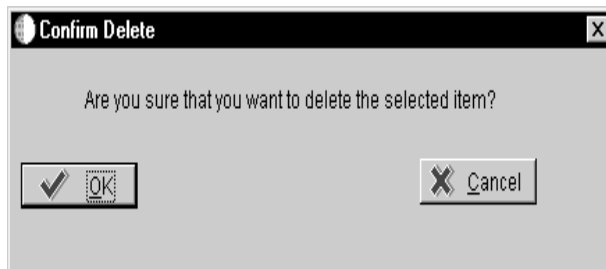



## Activating a Workflow Process

---

After you create the activities within the process, add activity conditions, and distribution lists, you must activate the process before you can attach it to an application.

When you activate the Workflow process, the system automatically verifies that all subprocesses and activities within the process contain a start and an end point. It also verifies that all activities that need event rules contain event rules, and that relationships exist between all activities and activity conditions. If the process cannot be verified, it is not activated. You cannot activate a process if it contains errors.

When a Workflow process is active, you can only edit recipient rules and activity descriptions. If you must edit an active Workflow process or one that contains instances, you must purge the process instance data if present, deactivate the process, and then edit it. You can also copy a version of a process and rename it.

See *Purging Workflow Data Files* for more information about purging data.

### **To activate a Workflow process**

---

1. From Workflow Management Setup (G0241), choose Process Master.
2. On Work With Processes, find and choose the process that you want to activate.
3. To activate the process, choose Activate from the Row menu.

If you want to deactivate the process, choose Deactivate from the Row menu. You have to deactivate a process if you want to modify it.



## Attaching a Process to an Application

---

After you have created and activated a process, you attach the process to an event within an application using Event Rules in Form Design Aid (FDA). You need only to define the system function Start Process in an application to attach a Workflow process. The Start Process system function invokes the activities within the process.

In the Credit Limit Changed example, the Start Process system function is attached to the Update to DB Before event in the Revise A/R Information application (P0301) on the Credit Information form. In this example, the Start Process system function invokes the activities that send an approval message and update the credit limit.

You can also attach Workflow processes in event rules within Report Design Aid (RDA), Table Design Aid (TDA), or through named event rules (NER). Note, though, that you should not attach a Workflow process that initiates interactive applications or executables through RDA, TDA, or NER because they typically run on the server; therefore, no one ever sees the applications initiated by the process. Use discretion when designing processes that run on servers.

In this example, the highlighted row of logic is the system function logic that starts the Workflow process.

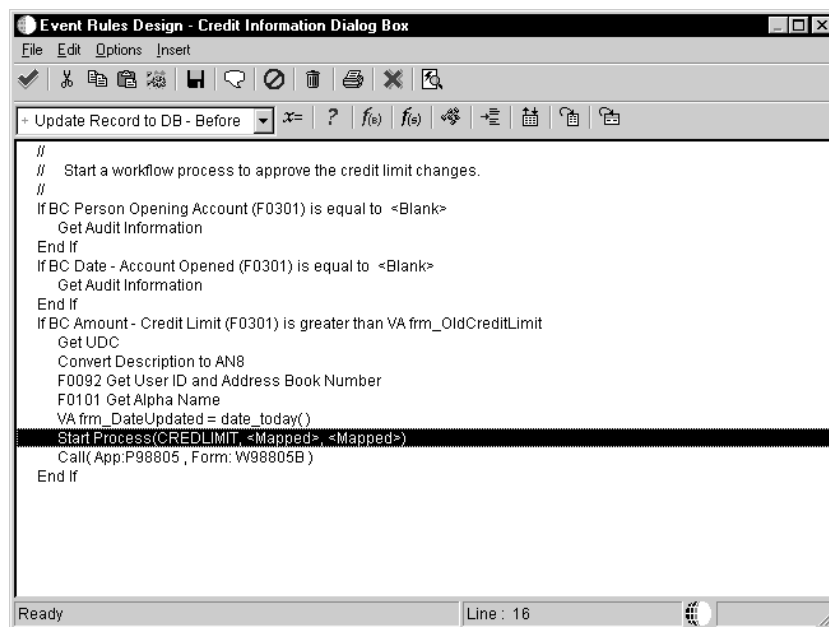

```
Event Rules Design - Credit Information Dialog Box
File Edit Options Insert
+ Update Record to DB - Before
//
// Start a workflow process to approve the credit limit changes.
//
If BC Person Opening Account (F0301) is equal to <Blank>
  Get Audit Information
End If
If BC Date - Account Opened (F0301) is equal to <Blank>
  Get Audit Information
End If
If BC Amount - Credit Limit (F0301) is greater than VA frm_OldCreditLimit
  GetUDC
  Convert Description to AN8
  F0092 Get User ID and Address Book Number
  F0101 Get Alpha Name
  VA frm_DateUpdated = date_today()
  Start Process(CREDLIMIT, <Mapped>, <Mapped>)
  Call(App:P98805, Form:W98805B)
End If
Ready Line: 16
```

The following tasks explain how to attach the process called CREDLIMIT to an application and how to call a “pending approval” message that appears within the Credit Master application when a user makes a change to a customer’s credit limit. This example is specific to the Credit Limit Changed process; the way in which you attach your processes varies.

Complete the following tasks:

- Attach the Start Process to an application
- Attach a form interconnection

## Before You Begin

- Understand how to attach event rules to applications. See *Event Rules* in the *OneWorld Development Tools Guide*.

### ► To attach the Start Process to an application

1. From the Object Management Workbench, find and check out the application. For example, check out P0301 - Revise A/R Information. See *Object Management Workbench* in the *OneWorld Development Tools* guide for detailed information about navigating in the Object Management Workbench.
2. Click the Design button in the center column.
3. On Interactive Application Design, click the Design Tools tab.
4. Click Start Form Design.
5. Find the form to which you want to attach the Start Process.

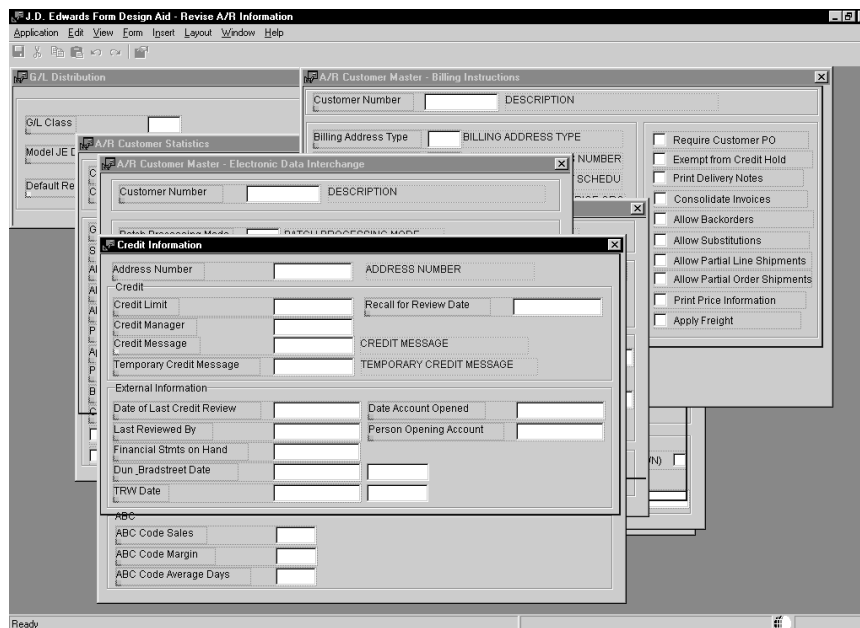

- Open the event rules for the form, position the cursor where you want to add the Start Process, and click the System Function button.

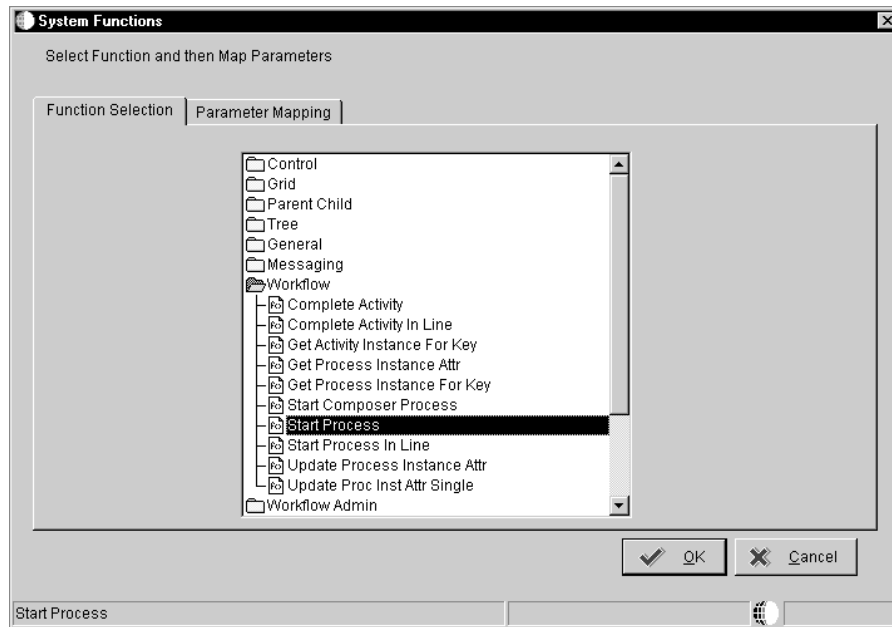

- On System Functions, click the Function Selection tab, double-click the Workflow folder, and then choose Start Process.
- Click the Parameter Mapping tab and double-click Choose Process.
- On Process Search and Select, find the process that you want to attach to the application and click OK.

The Workflow engine only runs an active process. If you have two versions for a process, such as with CREDLIMIT version 1 and CREDLIMIT version 2, it will run the active version, CREDLIMIT version 1.

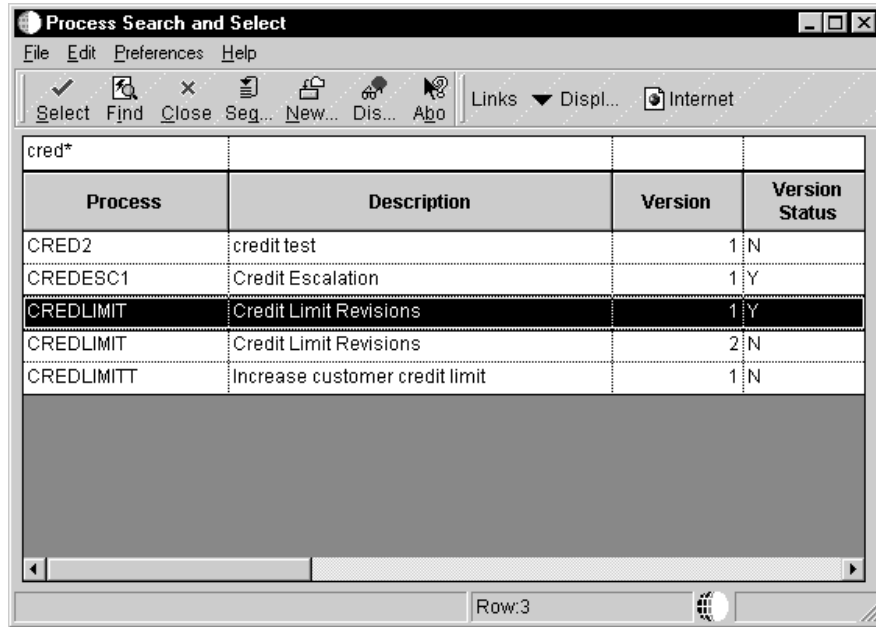

10. On System Functions, choose the Key DS data item, and double-click the Define Mapping object.
11. On Data Structure Mapping, map the Key DS to the corresponding object in the Available Objects list.
12. Map the Attributes DS and click OK.

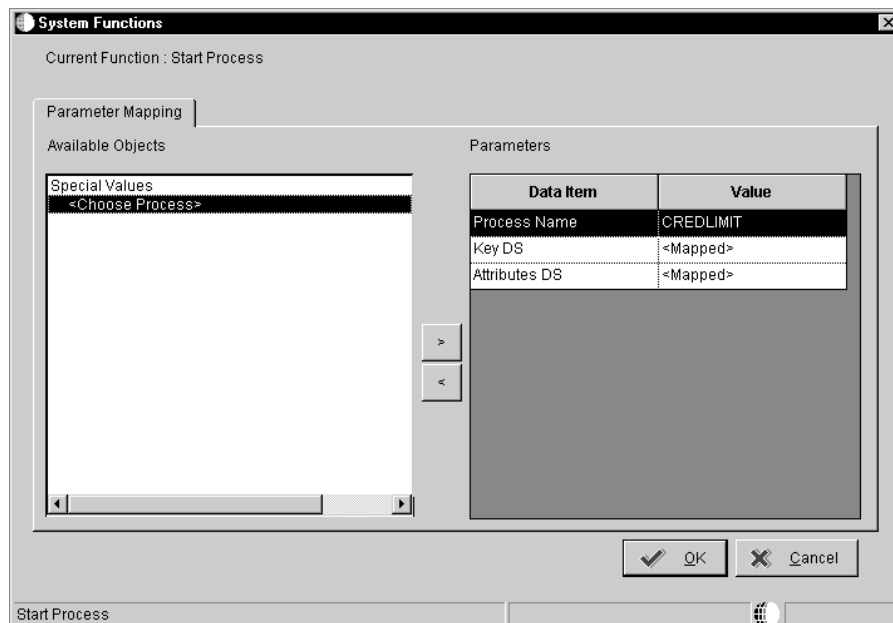

### See Also

- *Appendix B: System Functions* for information on message system functions and workflow system functions

### ▶ **To attach a form interconnection**

---

You can attach a form interconnection event rule that calls a message form. For example, you might want the system to call a form that notifies a user that the requested changes are made, pending approval from others.

1. On Event Rules, click the Form Interconnect button.
2. On Work With Applications, find and choose the application that you want to use.
3. On Work With Forms, choose the form that you want to use.
4. On Form Interconnections, map the appropriate parameters, if applicable.

In the Credit Limit Changed example, the form that is called when a user makes a change to a customer's credit limit is used for informational purposes only. Therefore, you do not need to pass any values to this form.

### See Also

- *Event Rules Design* in the *OneWorld Development Tools* guide for information about attaching event rules to applications
- *Appendix B: System Functions* for information about message system functions and workflow system functions





## Using Visio to Set Up Workflow Processes

You can use the Visio Professional graphical display tool to set up your Workflow processes. Visio Professional simplifies the setup process because Visio lets you drag activity icons and connectors onto a page, rather than choosing each application from the OneWorld menu. The system starts the appropriate application according to the icon that you drag to the page.

This section describes the following:

- Setting up Workflow activities in Visio
- Working with an existing Workflow process in Visio
- Using editing tools in Visio

### Before You Begin

- Install Visio Professional 5.0 on your workstation.





## Setting Up Workflow Activities in Visio

---

After you set up a workflow process through Process Master (P98800), you can use Visio to graphically add activities and rules to the workflow process. Visio shows you how each activity is connected to the other, which helps you decide where an activity or activity condition should be placed in the process, or where a subprocess should exist.

Complete the following tasks:

- Specifying Visio as the design interface
- Attaching activities to a process in Visio
- Attaching activity conditions to activities in Visio
- Attaching a plain connector to activities in Visio
- Viewing activity condition text in Visio

### Specifying Visio as the Design Interface

Before you can begin adding activities and rules in Visio, you must activate the processing option that invokes the Visio application.

#### **To specify Visio as the design interface**

---

1. From Workflow Management Setup (G0241), right-click Process Master.
2. Choose Prompt for Values from the drop-down list.
3. On Processing Options, choose the Graphics tab.
4. Enter 1 to invoke Visio as the primary design interface and click OK.

### Attaching Activities to a Process in Visio

After you set up a process, you attach activities to it. You can attach the following activities to a process through Visio:

- Function

- Batch Application
- Executable
- Interactive Application
- Message
- Halt Process
- Process

Visio Professional contains several icons and connectors that you use to attach activities to the process. The palette on the left of the Visio desktop contains all the icons and connectors that you need to set up your process.

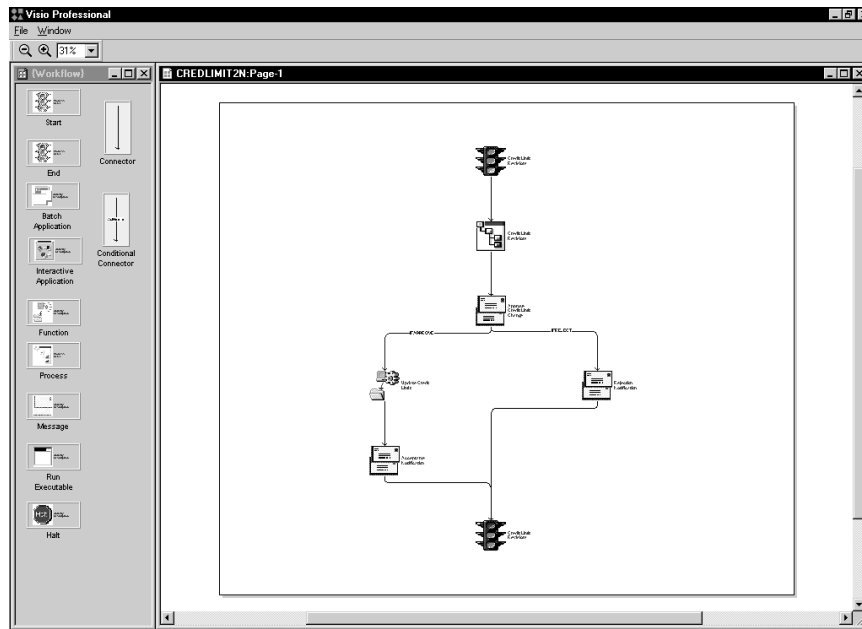

Following is an explanation of each icon and connector:

- |                                |   |
|--------------------------------|---|
| <b>Plain connector</b>         | Attaches activities to the start and end points of a process.             |
| <b>Start</b>                   | Identifies the beginning of the process.                                  |
| <b>End</b>                     | Identifies the end of the process.  |
| <b>Batch application</b>       | Identifies this activity as one that launches a batch process or report.  |
| <b>Interactive application</b> | Identifies this activity as one that launches an interactive application. |

<b>Business function</b>	Identifies this activity as one that attaches a function for special logic processing. For example, the Update activity in the Credit Limit Changed example is a business function that updates the database with changes.
<b>Process</b>	Identifies this activity as a subprocess.
<b>Message</b>	Identifies this activity as one that sends a message to a user or users.
<b>Connector with criterion</b>	Attaches activity conditions to activities.
<b>Run executable</b>	Identifies this activity as one that launches an executable program, such as a word processing or spreadsheet application.
<b>Halt Process</b>	<p>Identifies this activity as one that halts the process. The process will not automatically restart. You can run a batch process to restart any halted processes.</p> <p>The Check for Expired Activities (R98810) monitors processes that have been halted.</p>

### ► To attach activities to a process in Visio

---

1. From the palette, drag the icon that corresponds to the activity that you want to attach to the process. Drop the activity between the start and end icons of the process.

When you drop the activity icon onto the desktop, the system invokes the Activity Revisions form.

2. On Activity Revisions, create your activity as described in *Adding Activities to a Process*.

## Attaching Activity Conditions to Activities in Visio

You use the Connector with Criterion to attach activity conditions to activities. After you attach a connector to an activity, you can move the connector around, if necessary.

When you have finished creating the process and close and save the application, Visio deletes any connectors that are not attached to activities.

## ► To attach activity conditions to activities in Visio

1. Drag the Connector with Criterion onto the desktop and attach it to each activity that will be associated with this condition.

**Note:** To add a new activity condition, click Add on Process Rule Search & Select and follow the steps as described in *Adding Activity Conditions*.

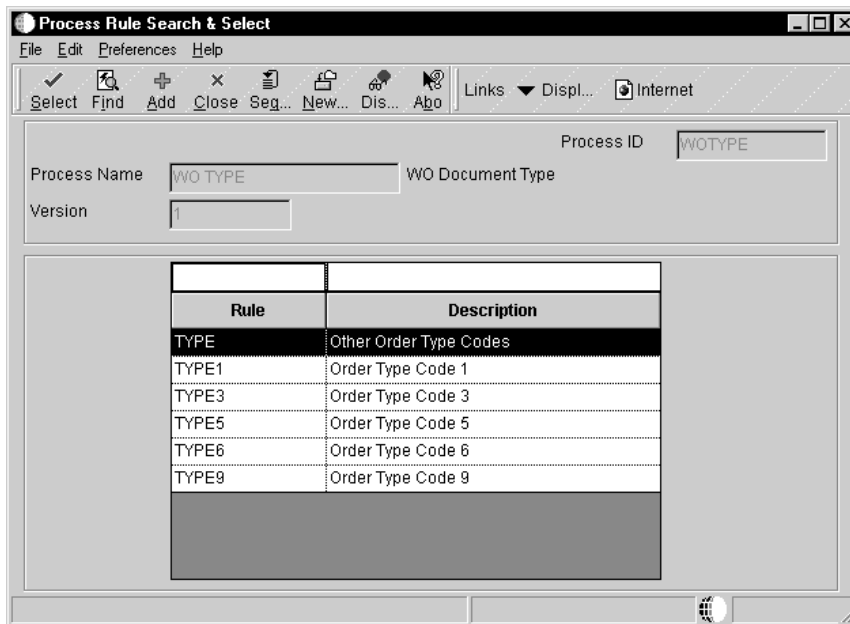

2. On Process Rule Search & Select, click Find to view all the activity conditions associated with this process.
3. Choose the condition that you want to attach to the activity and click Select.

The system returns to Visio. The connector associated with the activity condition appears on the desktop.

4. Drag one end of the connector to each activity. When you drag the connector, a small black box appears, which indicates the connection point of the connector. Attach the connection point to each activity.

**Note:** If the connector is attached properly, you see a small red box at the connection point between the connector and the activity. A small green x means that the connector is not attached properly.

You can also right-click the activity to which the connector is attached, choose View, and then choose Connection Points. Small gray x's appear at each of the connection points to which the connector is attached.

## Attaching a Plain Connector to Activities in Visio

You use the plain connector to attach activities to the start and end icons in the process.

### ▶ **To attach a plain connector to activities in Visio**

---

In Visio Professional, drag the plain connector to the desktop and attach it to an activity, and the start or end icon of the process.

**Note:** If the connector is attached properly, a small red box appears at the connection point between the connector and the start or end of the process. A green x means that the connector is not attached properly.

You can also right-click on the activity to which the connector is attached and choose View, Connection Points. Small gray x's appear at each of the connection points to which the connector is attached.

## Viewing Activity Condition Text in Visio

You can view the activity condition text (or conditional rule text) so you know which conditions are attached to your activities.

### ▶ **To view activity condition text in Visio**

---

1. In Visio Professional, right-click anywhere on the desktop.
2. Choose Activity Conditions Text.

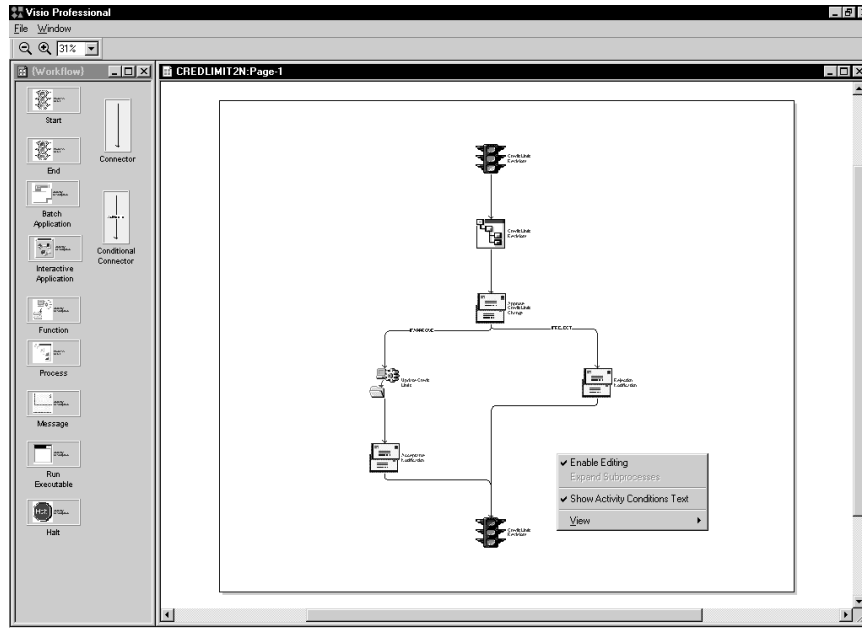

The system displays the activity condition text for each activity condition within the process.

## Working with an Existing Workflow Process in Visio

---

You can use Visio to modify existing Workflow processes. For example, you can use Visio to add a new activity to a process or change an activity condition in a process. When you work with an existing process in Visio, you can see where each activity and activity condition occurs in a process.

You can also view all subprocesses within a process by expanding all of them or just one, which is helpful if you need to modify activities or conditions within a subprocess.

**Note:** If you edit a process outside of Visio, the file that saves the last known Visio drawing will be removed and re-drawn when Visio is opened the next time. This procedure might change the appearance of how the icons in Visio were arranged.

Complete the following tasks:

- Modifying a process and its activities in Visio
- Viewing subprocesses in Visio

### Before You Begin

- Make sure that you have activated the graphic display processing option before you open the process. Otherwise, the system does not invoke Visio.

## Modifying a Process and its Activities in Visio

When you modify a process and its activities in Visio, you must enable editing, then make changes as necessary.

### ► To modify a process and its activities in Visio

---

1. From Workflow Management Setup (G0241), choose Process Master.
2. On Work With Processes, find and choose the process that you want to modify.
3. From the Row menu, choose Process Relationships.

The system opens the process in Visio.

4. Right-click anywhere on the desktop and choose Enable Editing.

After you enable editing, you can delete or add icons and connectors to the Workflow process.

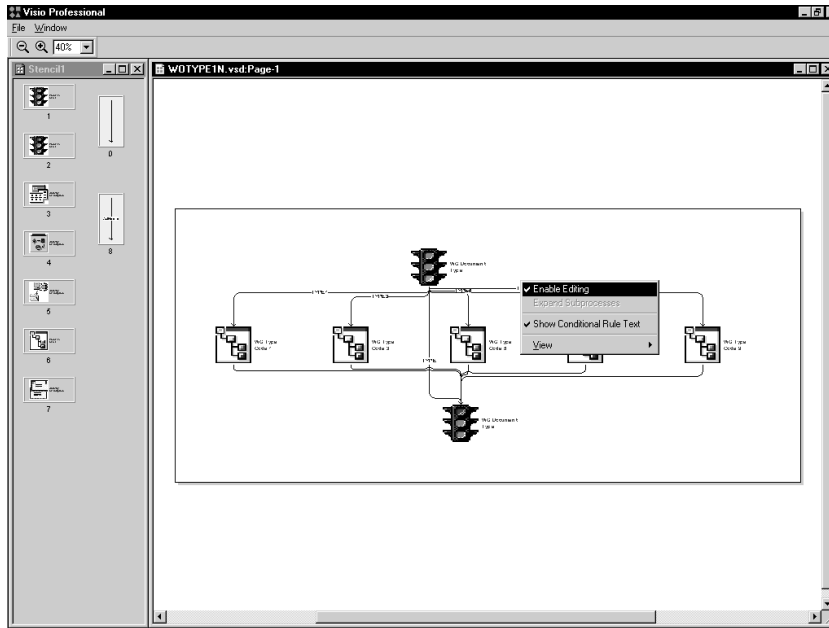

5. Modify the process and activities as necessary.

## Viewing Subprocesses in Visio

Some processes contain numerous subprocesses, which you cannot see in Visio unless you expand the view. You can expand the view so that you can see subprocesses for all processes within Visio, or you can expand the view to see the subprocesses of just one process.

**Note:** You cannot expand the view of processes in Edit mode. You must turn off the Enable Editing option before expanding processes.

Complete the following tasks:

- Expand view of all processes in Visio
- Expand view of one process in Visio

### ► To expand the view of all subprocesses in Visio

---

1. In Visio Professional, right-click anywhere on the desktop.

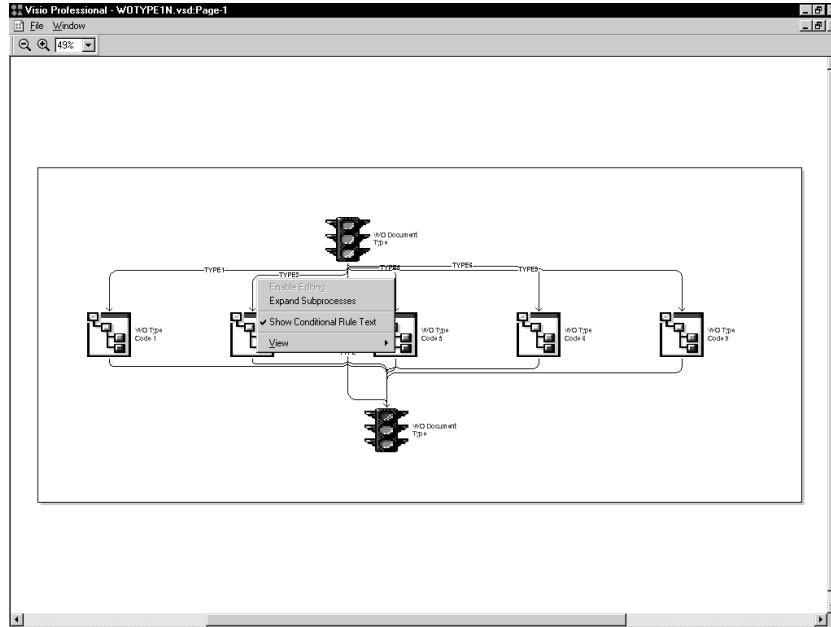

2. Choose Expand Subprocesses.

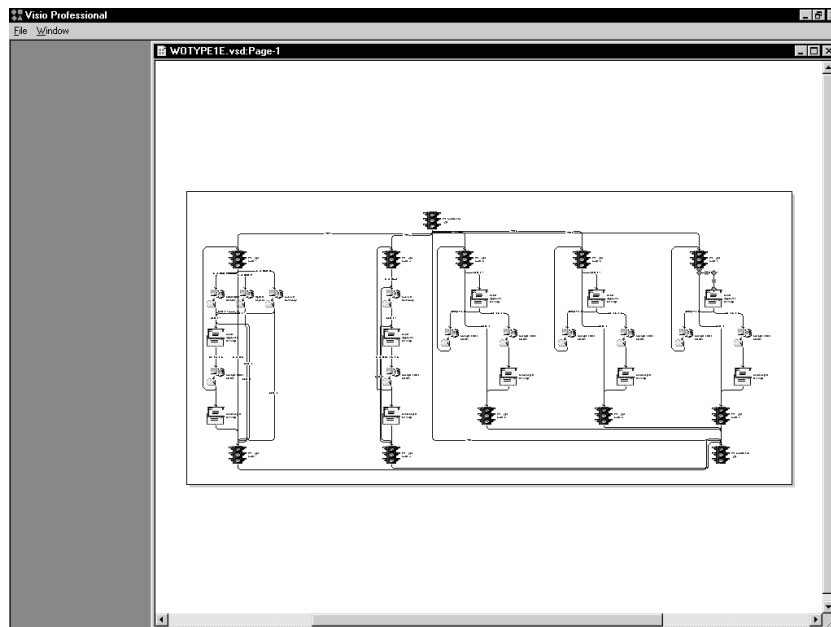

The system displays all subprocesses within the the processes.

3. After you expand the subprocesses, you can right-click and choose Compress Subprocesses to return to the original view.

## ► To expand the view of one process in Visio

1. In Visio Professional, right-click on a process icon.

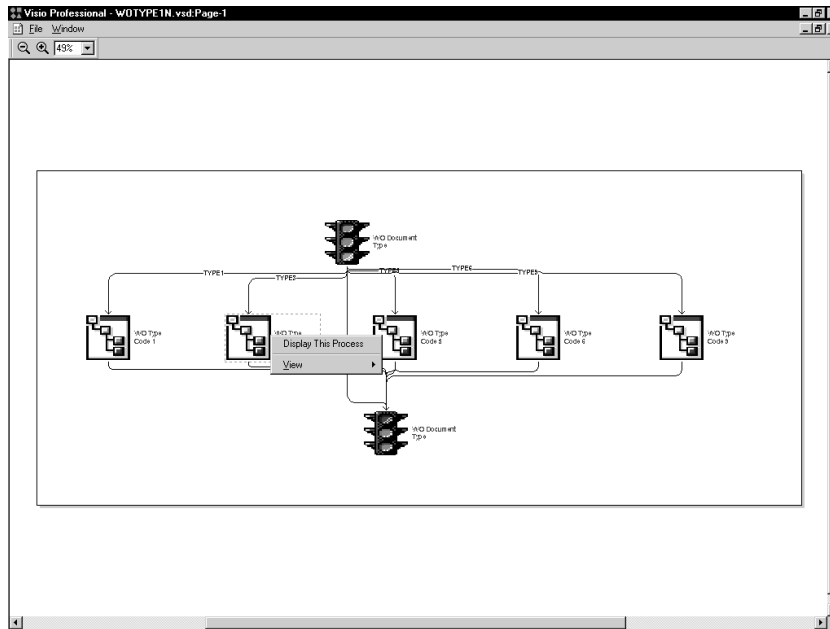

2. Choose Display This Process.

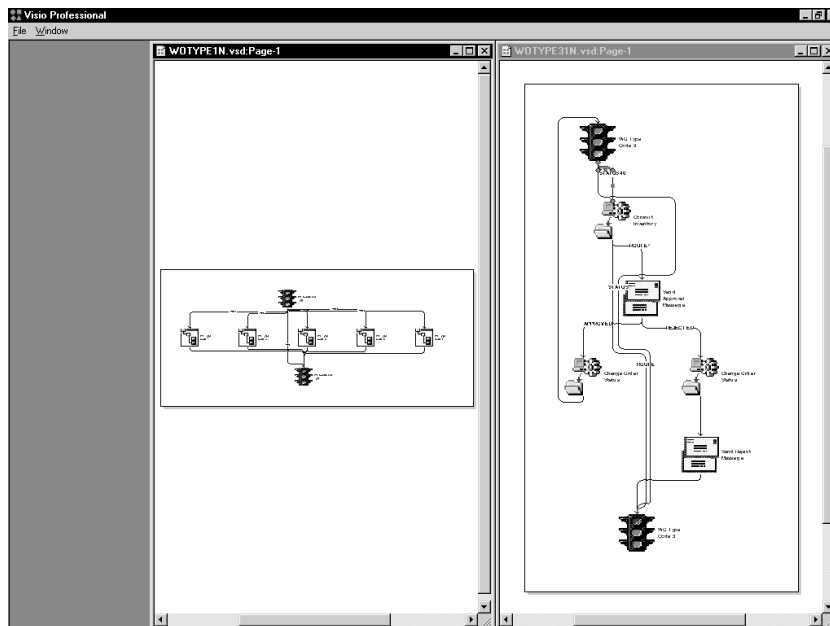

The system displays the subprocesses within the process that you chose.

## Using Editing Tools in Visio

---

You can use various editing tools within Visio to make your work easier. For example, you can zoom in on a particular part of a process, view the ruler and guides to arrange the process evenly on the desktop, or move connectors.

The following topics are described:

- Using the magnification option
- Viewing the ruler, the grid, and the guides
- Printing activity condition text
- Moving connectors

### Using the Magnification Option

You can increase or decrease magnification of the desktop so that you can view a few details of the process or view all details of the process.

#### **▶ To use the magnification option in Visio**

---

1. In Visio Professional, right-click anywhere on the desktop.
2. Choose View, and then one of the magnification options.

### Viewing the Ruler, the Grid, and the Guides

You can turn on the ruler, the grid, or the guides. The ruler shows measurement at the scale of the drawing. The grid and guides help you align icons and connectors on the desktop.

## ► To view the ruler, grid, and guides in Visio

---

In Visio Professional, right-click anywhere on the desktop and choose one or more of the following:

- Ruler
- Grid
- Guides

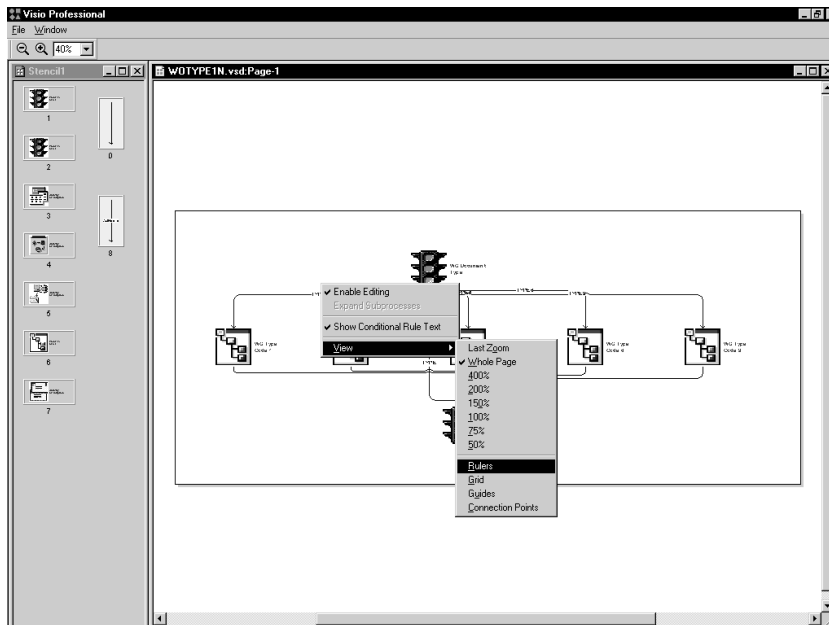

## Printing Activity Condition Text

You can print a copy of a Workflow process from Visio if necessary. However, if you want the text for activity conditions to appear when you print the process, complete the following task. Otherwise, any activity condition text within your process will not appear on the printout.

## ► To print activity condition text from Visio

---

1. In Visio Professional, choose Print from the File menu.

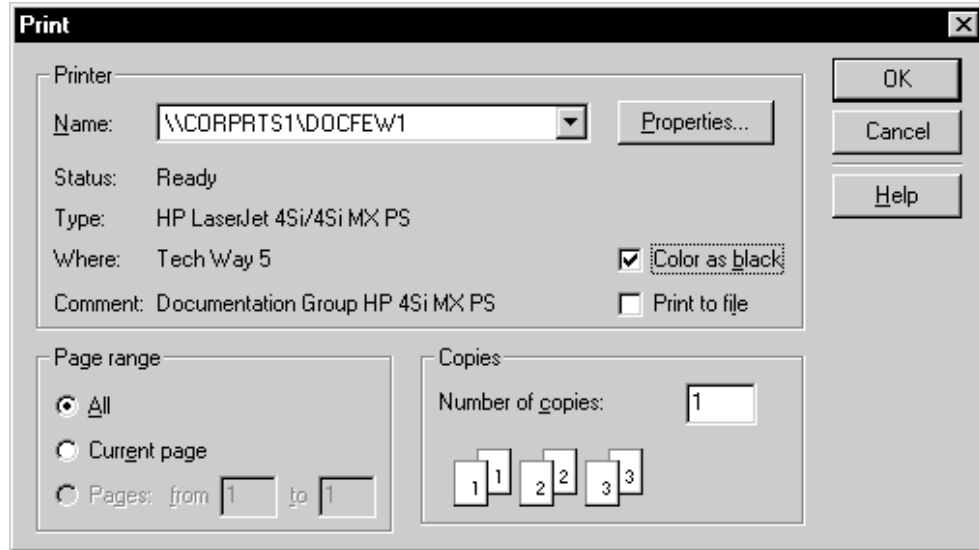

2. On the Print dialog box, choose the Color as black option, specify any other printing options, and click OK.

## Moving Connectors

You might want to move connectors around on the desktop if, for example, one connector overlaps another and you want to see the connector text for each connector.

### ► To move a connector in Visio

1. In Visio Professional, click the connector you want to move. Small green boxes appear along the length of the connector.

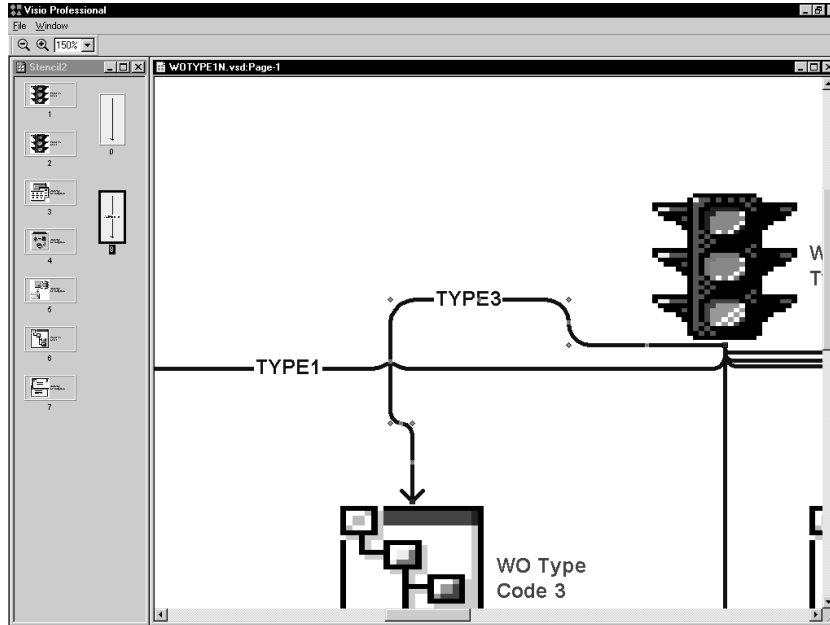

2. Drag any of the green boxes to the position you want.

## See Also

- Visio Professional online help for more information about how to use Visio Professional



## Administrative Tasks

Workflow allows you to complete administrative tasks such as monitoring an individual employee's queues or all the queues for each group within your organization. You can also analyze processes for improvement analysis, activate the escalation monitor, and copy process data to another data source.

You can monitor Accounts Receivable queues and Purchasing queues using the Workflow Advanced & Technical Operations menu (G0241). If necessary, you can add menu items that access other queues. For example, you can add a menu item to Advanced & Technical Operations that invokes Shop Floor Control queues.

See *Working with Menus* in the *OneWorld Foundation Guide* for more information about adding applications to menus.

This section describes the following:

- Monitoring process activity
- Changing queue security
- Activating the escalation monitor
- Analyzing Workflow processes
- Printing process instance reports
- Purging Workflow data files
- Managing Workflow processes





# Monitoring Process Activity

---

You use the Process Activity Monitor to monitor the process flow in the Workflow system and to retrieve audit data for process improvement analysis. You can also terminate, suspend, resume or override instances of a process. The Process Activity Monitor lists all of the activities that apply to the process and the status of each activity—for example whether the activity is complete or active. You can also review the resource (or employee) that was assigned to that activity, the start and end time of each activity, and the time and date that an activity expired.

Furthermore, you can review what was attached to messages when acted upon. You can also override the message approval process for messages that have not been answered by a lower level recipient. See *Understanding Distribution Lists* and *Setting Up Distribution Lists* for information about Higher Level Overrides.

The Process Activity Monitor also shows back-to-back processes (processes containing the same process keys). These back-to-back processes can become queued up until the first one is completed. For example, several credit limit change requests can be waiting to be accepted or rejected for the same primary key. These requests show a status of “Awaiting” until the first one is accepted or rejected.

This chapter describes the following tasks:

- Reviewing a process status
- Terminating, suspending, or resuming an instance of a process
- Reviewing attachments to an activity
- Overriding the message approval process

## Reviewing a Process Status

You review a process status to see if activities have been acted upon and to retrieve audit data.

### **To review a process status**

---

1. From Workflow Advanced & Technical Operations (G0231), choose Process Activity Monitor.

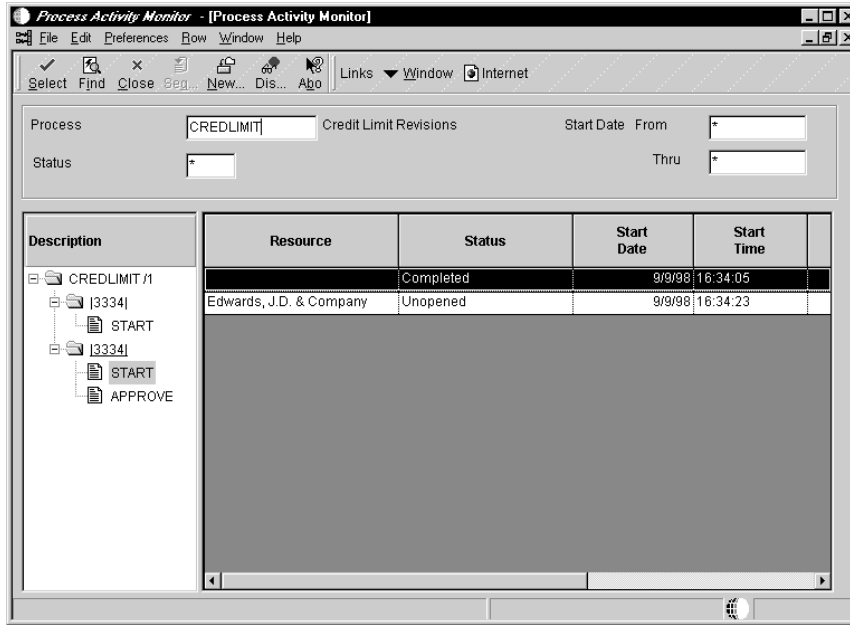

2. On Process Activity Monitor, complete the following field:
  - Process ID  
 Enter the name of the process for which you want to view activity.
3. Complete the following optional fields:
  - Process Status
  - Start Date From
  - Start Date Thru
4. Click Find to display the status of the process.

Field	Explanation
Process ID	The unique identifier for a process. If no value is entered, a next number is assigned. Once assigned, the value cannot be changed.
Process Status	The current status of a workflow process instance. Valid values are: Active Inactive Completed Suspended Terminated Error Awaiting

Field	Explanation
Start Date From	For a process, this is the date on which the workflow transaction was entered. For an activity, this is the date on which the activity was started within the process flow.
Description	A user defined name or remark.

## Terminating, Suspending, or Resuming an Instance of a Process

You might want to terminate an instance of a process if it contains errors or if the process cannot continue, such as when an employee has not yet answered his or her messages because he or she is on vacation or no longer works at the company. In this case, subsequent requests for the same process queue up behind the original request.

You might want to suspend an instance of a process if you want other processes to finish before a certain process. You can also restart a suspended instance of a process.

### ► To terminate, suspend, or resume an instance of a process

1. From Workflow Advanced & Technical Operations (G0231), choose Process Activity Monitor.
2. On Process Activity Monitor, find the process with which you want to work.
3. Choose one of the following from the Row menu:
  - Terminate
  - Suspend
  - Resume

## Reviewing Attachments to an Activity

You can review attachments associated with an activity. For example, if a recipient approves a message, then adds additional text to that message, and sends it, you can view that message text through an attachment from the Process Activity Monitor.

### ► To review attachments to an activity

1. From Workflow Advanced & Technical Operations (G0231), choose Process Activity Monitor.
2. Find the process with which you want to work.

3. Choose the row for which you want to view attachments.
4. From the Row menu, choose Attachments.

If an activity does not contain attachments, the Attachments option on the row menu is not enabled.

## Overriding the Message Approval Process

You might want to override the message approval process if a message has not been answered by a recipient in a lower level. For example, if a clerk has not approved or rejected a message and the manager wants the message to be approved to move it to the next level, the manager can override the approval process in the Process Activity Monitor and approve or reject the message himself. The manager can only override the message approval process for any messages sent to a distribution list that includes higher level overrides.

The Overrides option is enabled if all of the following conditions are met:

- You exist in the Address Book.
- You are a member of a higher level group than the recipient for whom the message was intended.
- The message is unopened.
- The message has an active shortcut.

See *Understanding Distribution Lists* and *Setting Up Distribution Lists* for more information about Higher Level Overrides.

### **To override the message approval process**

---

1. From Workflow Advanced & Technical Operations (G0231), choose Process Activity Monitor.
2. On Process Activity Monitor, find the process and activity with which you want to work.
3. Choose the row for which you want to override message approval.
4. Choose Override from the Row menu.

The system displays the Higher Level Override form.

5. Accept or reject the message.

The system returns to Process Activity Monitor.

6. Click OK.

## Changing Queue Security

---

You can change the security status for a user or group of users within a message queue. You can either give a user authority to monitor queues within a group or give public security to queues for all groups.

You can add security by user, by distribution list, or both. For example, you might want to set up security for a manager so that he or she can monitor all messages within a group for certain queues. Or you might set up security by distribution list only so that users within a distribution list have authority to monitor messages within a group for certain queues. If you want to give only a few people within a distribution list access to certain queues, you enter the user's address book number and the distribution list to define which queues that user in a particular distribution list can access.

**Note:** Using Queue manager to view mail ignores security and all messages can be viewed.

Complete the following tasks:

- Specifying the queues that a user can view in a group
- Changing public security

## Specifying the Queues that a User Can View in a Group

When you set up a new user in a distribution list, you must specify which queues that the user can view within that group.

### **To specify the queues that a user can view in a group**

---

1. From Workflow Management Setup (G0241), choose Queue Security.

2. On Work With Workflow Message Security, click Add.

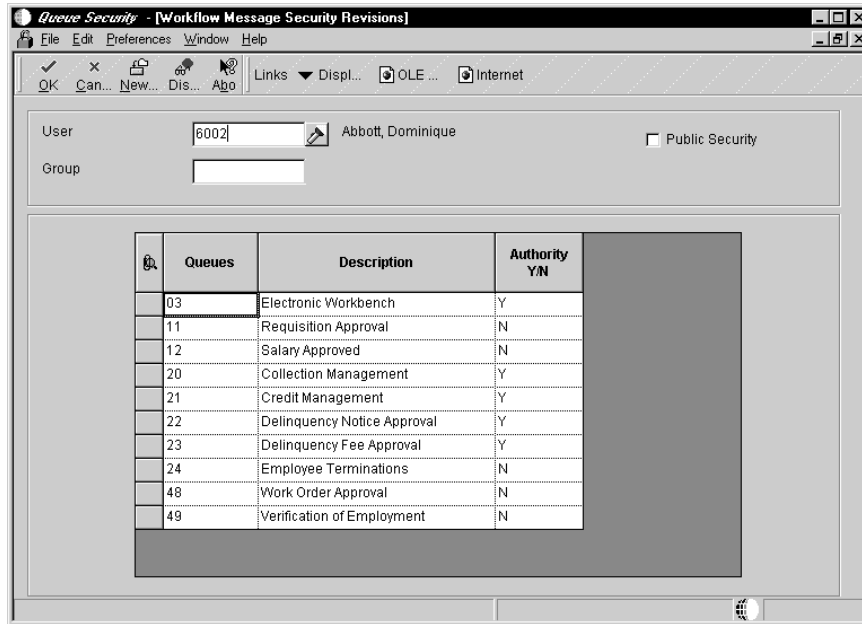

3. On Workflow Message Security Revisions, complete the following fields:
  - User
  - Group
4. Specify the queues that a user can view by completing the following field and clicking OK:
  - Authority Y/N

In this example, Dominique Abbot has access to the Electronic Workbench, Collection Management, Credit Management, Delinquency Notice Approval, and Delinquency Fee Approval queues for group X. Therefore, she can monitor all messages within these queues for group X.

Field	Explanation
User	A user in the workflow system. This can also be a group.
Group	A group or list of users in the the workflow system. This is the number of the workflow distribution list.
Authority Y/N	Indicates whether the user is authorized to make changes to security information. ..... <i>Form-specific information</i> ..... For workflow, indicates whether the user can view other queues in the Work Center.

## Changing Public Security

When you assign the Public Security option, all users have access to queues that you specify. For example, if you choose the Public Security option and give authority to the Collection Management queue, all users in the system are able to view all messages in that queue.

### ► To change public security

1. From Workflow Management Setup (G0241), choose Queue Security.
2. On Workflow Message Security Revisions, complete the following fields and click OK:
  - Public Security

When you choose this option, the system protects the User and Group fields because you are specifying that you want to give authority to specific queues to all users in the system.

- Authority Y/N

**Note:** If you complete the user field, the system protects the Public Security field.

Field	Explanation
Public Security	Workflow security records can be set up so that all or *PUBLIC users have access to specific queues. By choosing this option, any queue that has been selected by placing a Y next to it will have a *PUBLIC record written for it. This will allow any user to view any other user's messages in this queue.

### See Also

- *User Defined Codes* in the *OneWorld Foundation Guide*



# Activating the Escalation Monitor

---

The escalation monitor, or Check for Expired Activities batch process (R98810), checks for any Message activity instances that have escalation associated with them. When the monitor finds Message activities with escalation, it forwards those messages that have not been acted upon after a specified period of time to the next user. It also resumes Halt activities.

This chapter describes how to start the escalation monitor manually by submitting its batch version, as you do with any other batch process. However, the Scheduler application provides a convenient alternative for automatically restarting the escalation monitor at predefined intervals.

See *Scheduling a Job* in the *System Administration Guide* for more information.

**Caution:** If the Scheduler is not used, you should restart the escalation monitor each time that it stops, with an acceptable duration in between depending on the urgency of Halts and Escalations. The Escalation Monitor does not automatically restart. If you do not restart the monitor, the processes that contain messages with escalation will not be reactivated. Instead, they will remain in a suspended state until you restart the monitor. Therefore, it is beneficial to use the Scheduler application to automatically restart the escalation monitor for you.

## ► To activate the escalation monitor

---

1. From Workflow Management Setup (G0241), choose Workflow Advanced & Technical Operations (G0231), and then Start Escalation Monitor.
2. On Work With Batch Versions, choose version XJDE0002.
3. On Version Prompting, choose any of the following, if necessary, and click the Submit button:
  - Data Selection
  - Data Sequencing

When you run the monitor, the system produces a summary of Message and Halt Process activities that have not been completed yet.

## See Also

- *Adding a Message Activity* for information about monitoring for escalation in message activities

- *Scheduling Jobs* in the *OneWorld System Administration* guide for information about automatically restarting the escalation monitor (Check for Expired Activities batch process - R98810)

# Analyzing Workflow Processes

---

You analyze Workflow processes using the Advanced Analysis application. Through Advanced Analysis, you can see how long it takes for a process to run and where processes might be queued up. This analysis can help you make your processes more efficient and less time consuming. You can view an analysis using actual or average duration in days or hours, depending on your needs.

You can export the data displayed in the Advanced Analysis form to a spreadsheet, or create graphs and charts of the information. See the *OneWorld Foundation Guide* for more information about these options.

You can use several combinations of process, activity, version, and instance to analyze process data. Following are some possible combinations:

<b>Process, version, instance, actuals</b>	The actual duration for each instance of the process and version from the Process Instance table (F98860).
<b>Process, version, instance, activity, actuals</b>	The actual duration for each activity within each instance from the Activity Instance table (F98865).
<b>Process</b>	The average duration for all versions of a process.
<b>Process, version, averages</b>	The average duration of the instances for that version. The instances are averaged together, regardless of the instance keys.
<b>Process, version, instance, averages</b>	The average duration for instances, if instances with the same key exist.
<b>Process, version, instance, activity, averages</b>	The average duration for each activity within the instance, if instances with the same key exist.
<b>Process, instance, activity, averages</b>	The average of activities for like instance keys across versions.

<b>Process, version, activity, averages</b>	The average duration for each activity across instances. The activities are averaged together, regardless of whether the instances to which they belong have the same key.
<b>Process, activity, averages</b>	The average of activity duration across versions.
<b>Process by user</b>	The average duration for all versions of the process for which that the user is responsible.
<b>Process, version, by user</b>	The average duration of the instances for that version for which the user is responsible. The instances are averaged together, regardless of the instance keys.
<b>Process, version, instance, by user</b>	The average duration for instances with the same key for each responsible user.
<b>Process, version, instance, activity, by user</b>	The average duration of each activity within instances that contain the same key for each responsible user.
<b>Process, instance, activity, by user</b>	The average of activities for like instances keys across versions for each responsible user.
<b>Process, version, activity, by user</b>	The average duration for each activity across instances for which the user was responsible. The activities are averaged together, regardless of whether the instances to which they belong have the same key.
<b>Process, activity, by user</b>	The average of activity duration for each responsible user.

### ► **To analyze a process**

---

From Workflow Advanced & Technical Operations (G0231), choose Advanced Analysis.

If you choose Actuals, the system automatically includes the process, version, and instance in the analysis. You can choose whether to include activity in the analysis.

If you choose Average, the system automatically includes the process in the analysis, and you can then choose whether to view averages based on version, instance, or activity.

If you choose the User option, a resource column appears in the detail area. The User column identifies the user who was assigned to that particular activity.

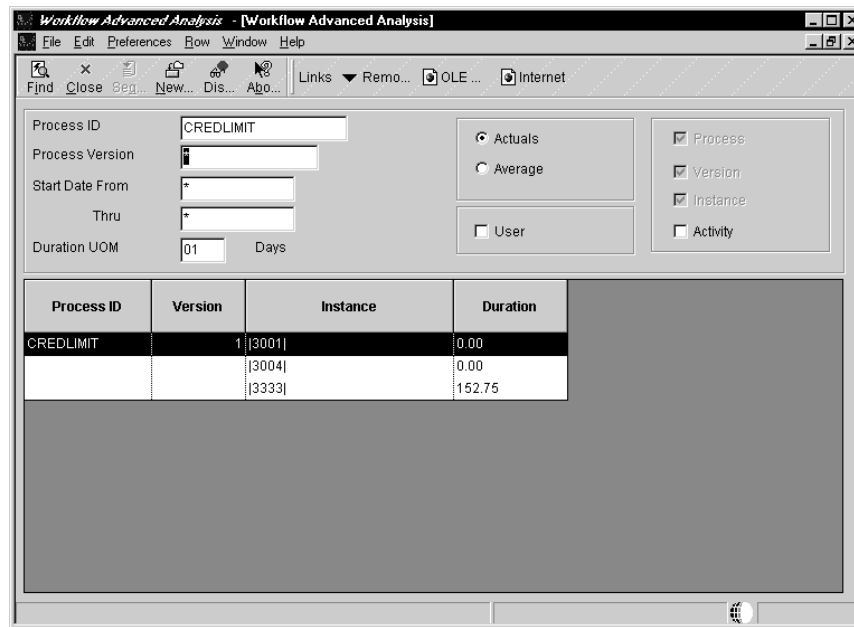

1. On Workflow Advanced Analysis, click Find to query all processes, or complete the following field and click Find to query a process:
  - Process ID
2. Complete the following optional fields:
  - Process Version
  - Start Date From
  - Thru
  - Duration UOM

To analyze a process by day or by hour, enter the appropriate unit of measure in this field. You can use the visual assist to make your choice.

3. Click one of the following options:
  - Actuals
  - Average
4. If you want to analyze the actuals for a process and you want to include activities in the analysis, click the following option:
  - Activity
5. If you want to analyze the averages for a process, click one or more of the following options:

- Version
  - Instance
  - Activity
6. If you want to view the user responsible for a process, click the following option:
    - User
  7. Click Find.

The system displays audit information based on your choices. You can manipulate the information in the grid (for example, you can graph, export, and print) like any other grid information.

8. If you want to remove a row of data (for example, if you want to create a graph of the data contained in the analysis but do not want to include certain rows of data), choose Remove Row from the Row menu.

The system removes the row from the grid but does not delete the information from the database.

<b>Field</b>	<b>Explanation</b>
Process ID	The unique identifier for a process. If no value is entered, a next number is assigned. Once assigned, the value cannot be changed.
Process Version	A number from 1 to 99999 that identifies a unique version of a workflow process.
Start Date From	For a process, this is the date on which the workflow transaction was entered. For an activity, this is the date on which the activity was started within the process flow.
Thru	For a process, this is the date on which the workflow transaction was completed. For an activity, this is the date on which the activity was completed within the process flow.
Duration UOM	The units in which the duration of time for a process, activity or instance should display.
Actuals	Indicates that the actual workflow instance data should be displayed.
Average	Indicates that the average workflow instance data should be displayed.
User	Indicates that the workflow data should be displayed by the responsible resource for the instance or activity.
Process	Indicates that the workflow data will be displayed by process.

<b>Field</b>	<b>Explanation</b>
Version	Indicates that the workflow data will be displayed by the version of a process.
Instance	Indicates that the workflow data will be displayed by instance, within a version for each process.
Activity	Indicates that the workflow data for each activity within a process will be displayed.



# Printing Process Instance Reports

---

You can print process instance reports to review information about the Workflow process activity on paper rather than online or to archive process activity information on paper for future reference.

## ▶ **To print process instance reports**

---

1. From the Workflow Advanced & Technical Operations menu (G0231), choose Process Activity Print.
2. Choose a version in the detail area and click Select.
3. On Version Prompting, choose any of the following, if necessary, and click the Submit button:
  - Data Selection
  - Data Sequencing
4. On Report Output Destination, choose one of the following and click OK:
  - On Screen
  - To Printer

### See Also

- *Submitting and Printing Reports* in the *OneWorld Enterprise Report Writing* guide for more information about how to submit reports



## Purging Workflow Data Files

---

In order for Workflow to run, it must create Process Instance (F98860) and Activity Instance (F98865) records. If you choose to have your Workflow process retain these records for historical purposes, the files will become very large and occupy storage resources. The presence of large amounts of data in the F98860 and F98865 tables will also hinder performance of the Workflow engine.

You should purge Workflow data files periodically to minimize the amount of data in the tables and recover disk space. You can purge completed tasks or completed processes. Purging completed tasks deletes message activities, whereas purging completed processes deletes instances.

**Caution:** Purging data files might affect your metrics analysis. Because of this, J.D. Edwards recommends that you restrict access to this application.

Purging workflow data files contains the following tasks:

- Purging completed Workflow processes
- Purging complete Workflow tasks



### **To purge completed Workflow processes**

---

It is recommended that you purge completed processes regularly to minimize the amount of data in the tables. This process only purges records that don't affect active processes in the system and purges F98860 and F98865 records that possess a status of complete, terminated, or error.

1. From Workflow Advanced & Technical Operations (G0231), choose Data File Purges and then Purge Completed Processes.
2. On Work With Batch Versions, choose a version from the detail area and click Select.
3. On Version Prompting, click Data Selection and then click Submit. It is recommended that data selection be used when running Purge Completed Processes to further restrict the records that are being deleted.
4. On Printer Selection, choose your print destination and click OK.

### ► **To purge completed Workflow tasks**

---

Workflow tasks contain send message activities. Send message activities produce files that are used to record mail messages. Files containing these message activities can grow very large. Active Workflow messages which contain shortcuts to resume the Workflow process completely delete themselves from the database after they are executed, but Workflow messages that are not active do not. Non-active messages can be deleted manually from the Work Center queues, but they will not be removed from the database until they are removed from the deleted queue.

1. From Workflow Advanced & Technical Operations (G0231), choose Data File Purges, then choose Purge Completed Tasks.
2. On Work With Batch Versions, choose a version from the detail area and click Select.
3. On Version Prompting, click Data Selection or Data Sequencing and click OK.
4. On Printer Selection, choose your print destination and click OK.

# Managing Workflow Processes

---

You must be careful when promoting Workflow processes through the development cycle. Workflow processes follow a similar path as other OneWorld objects, but a full understanding of workflow components makes it easier for you to manage and deploy workflows to the end user.

A Workflow process consists of two basic components: Workflow data and object specifications. To move workflows between your Development and Testing environments requires that you copy workflow data and related object specifications.

Managing Workflow processes contains the following topics:

- Workflow data
- Object specifications
- Workflow deployment processes
- Copying process data to another source

## Workflow Data

Workflow tables reside in the Control Tables Data Source and contain Workflow process definitions, related activities, organizational structure, and other related tables as shown below:

<b>F98800</b>	Process Route Master
<b>F98800D</b>	Process Master Alternate Description
<b>F98800T</b>	Process Master Supplemental Information
<b>F98810</b>	Activity Master
<b>F98810D</b>	Activity Master Alternate Description
<b>F98811</b>	Activity Details

<b>F98830</b>	Process Activity Associations
<b>F98840</b>	Organizational Structure Master
<b>F98845</b>	Organizational Structure Rule

## Object Specifications

Object specifications reside in a data source for the path code, such as Central Objects-DEVB733, and include the key data structure, the additional data structure, and related programs.

## Workflow Deployment Processes

To deploy a workflow process, you must:

- Copy the process data to the desired location
- Transfer the objects used in the workflow
- Update your packages or build a full or partial package
- Deploy the workflow to testers or end users

Copying process data to another source is covered in this section. See *Object Transfer*, *Package Build*, and *Deployment*, in the *OneWorld Configuration Planning and Setup: Package Management* guide.

The following graphic illustrates the steps that are required to deploy a workflow process:

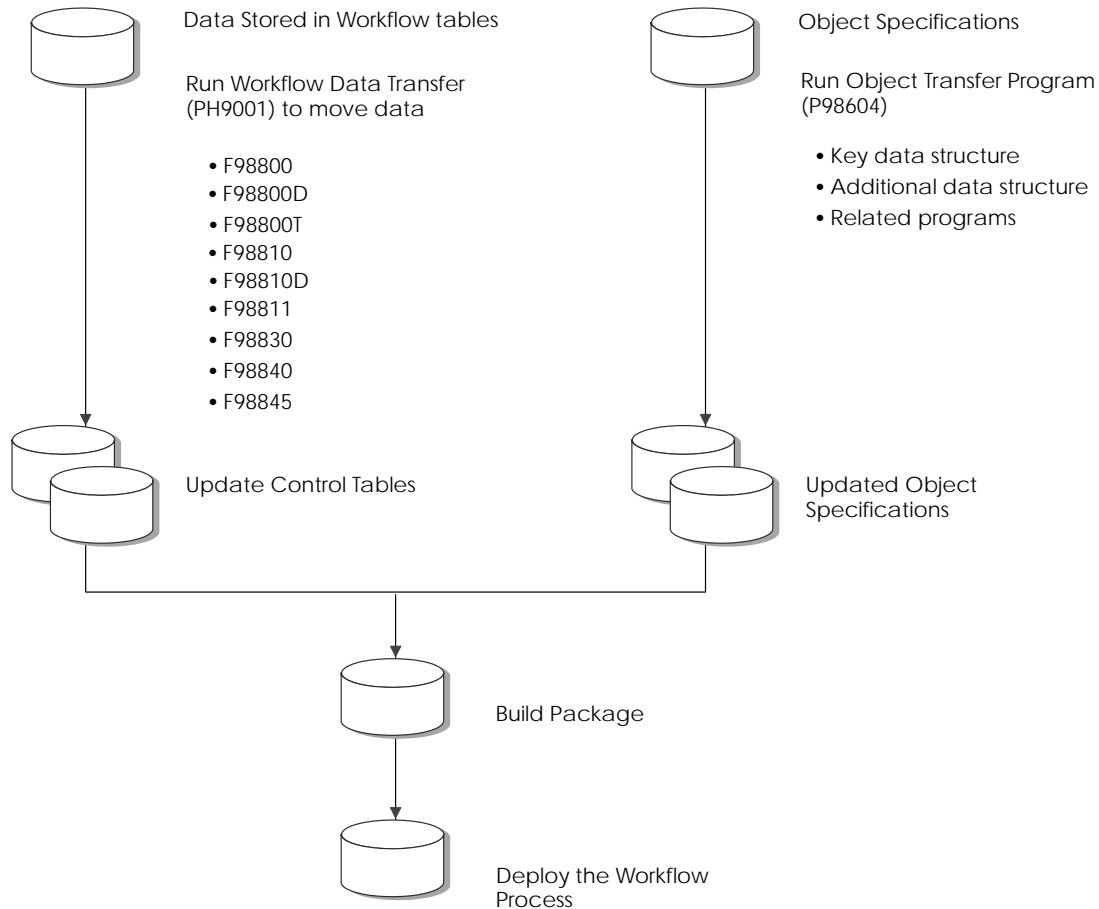

## Copying Process Data to Another Source

You may need to copy Workflow process data from one data source to another, if, for example, you created a Workflow process on a development server and, once complete and tested, you want to copy it to the production server. You can copy all processes or selected processes from one data source to another without losing data in the destination data source. If a process already exists in the destination source, the system replaces the existing definition with the new one. If the process definition does not exist, the system adds it.

Workflow data changes between releases. Not only does J.D. Edwards add and modify its own data, but users may have their own workflow data as well as modified J.D. Edwards data. Effective with B73.3.1 installations and upgrades, J.D. Edwards delivers and merges all J.D. Edwards workflow processes with user workflow processes.

**Note:** You cannot copy data into B73.3 or later from an earlier OneWorld release.

If necessary, you must ensure that you have ODBC drivers set up correctly to access the data. If your ODBC drivers are not set up correctly, the system does not copy the process data. Also, you must have authority to access the destination data source. If you do not have authority to a data source and you run a data merge, the data does not appear in the destination data source.

See the appropriate Microsoft documentation for information about ODBC drivers.

Beginning with OneWorld Xe, use the Object Management Workbench (OMW) to handle workflow data transfer instead of the Workflow Data Transfer application (PH9001). In the OMW, workflow data transfer is accomplished with object transfer activity rules. Consequently, you must add workflow processes that need to be copied from one data source to another to an OMW project.

Object transfer activity rules are usually set up by your system administrator. The rules dictated the source and target locations for transferring objects, and in the case of workflow processes, these values correspond to data source names. The rules are executed when a project is advanced from one status to another. The same transfer rules apply regardless of the sign-on environment.

**Note:** On AS400/DB2, the system uses a separate data source for F98811. For details on setting up transfer activity rules for F9811, see *Object Management Workbench Configuration* in the *OneWorld System Administration* guide.

### See Also

- The *OneWorld System Administration* guide for information about jde.log files and configuring the OMW
- The *OneWorld Development Tools* guide for information about Universal Table Browser and using the OMW



## Workflow Processing

Prior to B73.3.3, all workflow processes ran synchronously, or one after the other. Starting with B73.3.3., workflow-enabled applications can use asynchronous processing.

Asynchronous processing allows various workflow processes to run at the same time. By starting a workflow process asynchronously, you are simply running the workflow in the background of the calling application. Although asynchronous workflow processes may process faster, synchronous processing is sometimes preferred. If a calling application depends on information from the workflow process, you should run the workflow process synchronously to ensure that the calling application gets the information it needs from the workflow process before the workflow finishes and the application closes.

A workflow process runs asynchronously by default, with the following exceptions:

- When it contains a form interconnect or run executable activity
- When it is run from a batch application
- When the workflow process is specifically designed to run synchronously

The workflow runs either on the client or the server as determined by the default Object Configuration Manager mapping for business functions.

When the workflow runs on the client, it is started on another thread maintained by the runtime module. When the workflow runs on the server, it is started in a dedicated kernel type that must be created on the server. The new kernel definition must be added to the jde.ini on the server. The system administrator typically defines this setting in the jde.ini file.



The following illustration is a high-level flowchart of asynchronous processing:

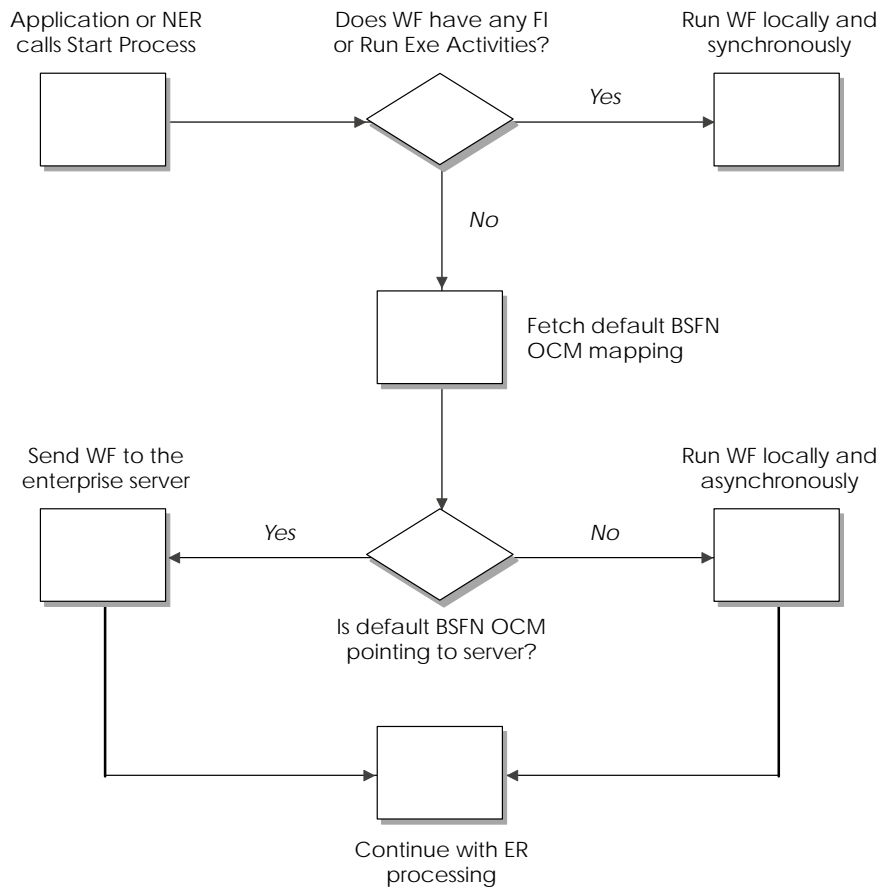

## Sign-On Environment Dependency

Workflow tables are not written when the sign-on environment is local, and the workflow is running on the server. The server cannot write to or update a database on a client workstation. When the sign-on environment is local, the workflow must run locally as well.

---

The following illustration shows a workflow process called from a named event rule. The workflow process always runs on the same machine as the name event rule.

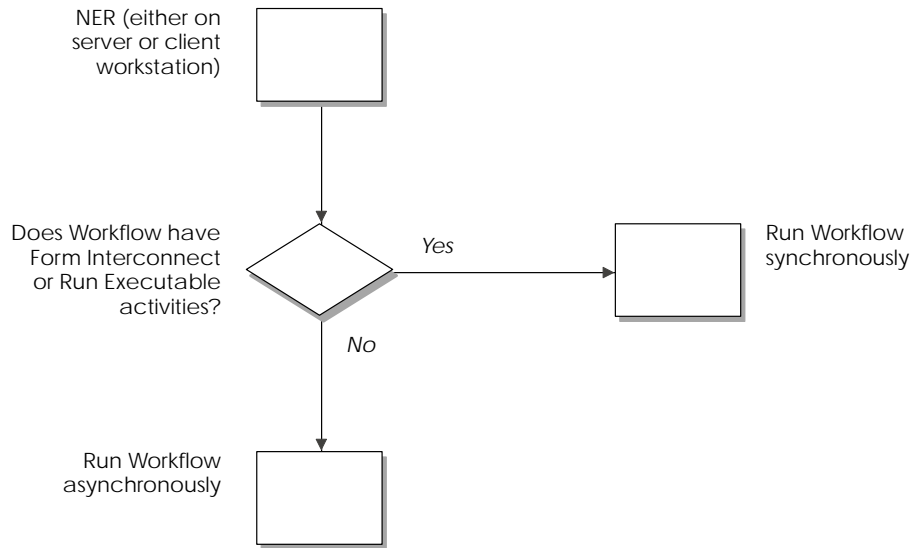

## Workflow System Functions

You can use the system functions, *StartProcess* and *CompleteActivity*, for asynchronous processing. You can use the system functions, *StartProcessInline* and *CompleteActivityInline*, for synchronous processing.

If an application depends on a workflow process to complete before continuing with subsequent event rule logic, then you must use *StartProcessInline*.

Several system functions for workflow processing are available. Refer to the Online APIs for more information about specific system functions.

## Transaction Processing

If a named event rule that is included in a transaction calls any workflow system function, regardless of whether the workflow processes are synchronous or asynchronous, the workflow process is not included in the transaction. Therefore, the workflow process is permanently written to the tables even if the transaction rolls back.

## Workflow Boundaries

The *StartProcess* and *CompleteActivity* system functions run asynchronously in interactive applications, named event rules (NER), and table event rules (TER).

The *StartProcessInline* and *CompleteActivityInline* system functions run synchronously in interactive applications, named event rules (NER), and table event rules (TER).

Workflow processes in batch applications and sub-process activities within a workflow always run synchronously, so only the *StartProcessInline* and *CompleteActivityInline* system functions are available in Report Design Aid and sub-process activity definition. All event rules for existing batch applications that call *StartProcess* and *CompleteActivity* continue to be displayed as they are, but the workflow processes run synchronously.

The following table illustrates various workflow scenarios. These scenarios assume that the workflow process does not include a form interconnection and does not run executable activities.

Scenario	System Function Used	Behavior of Workflow
UBE > Workflow	StartProcess/CompleteActivity (in existing applications)	Synchronous
UBE > Workflow	StartProcessInline/CompleteActivity-Inline	Synchronous
Application > Workflow	StartProcess/CompleteActivity	Asynchronous
Application > Workflow	StartProcessInline/CompleteActivity-Inline	Synchronous
UBE > NER/TER > Workflow	StartProcess/CompleteActivity	Synchronous
UBE > NER/TER > Workflow	StartProcessInline/CompleteActivity-Inline	Synchronous
Application > NER/TER > Workflow (Synchronous NER)	StartProcess/CompleteActivity	Asynchronous
Application > NER/TER > Workflow (Asynchronous NER)	StartProcess/CompleteActivity	Asynchronous
Application > NER/TER > Workflow	StartProcessInline/CompleteActivity-Inline	Synchronous
Application > Synchronous Workflow > NER activity > Workflow2	StartProcess/CompleteActivity	Workflow2 Asynchronous
Application > Synchronous Workflow > NER activity > Workflow2	StartProcessInline/CompleteActivity-Inline	Workflow2 Synchronous
Application > Asynchronous Workflow > NER activity > Workflow2	StartProcess/CompleteActivity	Workflow2 Asynchronous

---

Application > Asynchronous Workflow > NER activity > Workflow2	StartProcessInline/CompleteActivity-Inline	Workflow2 Synchronous with respect to the first workflow
Workflow > Workflow subprocess activity	StartProcess (in existing Workflow processes)/StartProcessInline	Synchronous



# Appendices



## Appendix A – Workflow Tables

---

Listed below are the tables that are used by the Enterprise Workflow Management system.:

<b>Address Organization Structure Master File</b>	F0150
<b>Workflow Message Security</b>	F01137
<b>Process Route Master</b>	F98800
<b>Activity Master</b>	F98810
<b>Activity Specifications</b>	F98811
<b>Process Activity Associations</b>	F98830
<b>Organizational Structure Master</b>	F98840
<b>Organizational Structure Rule</b>	F98845
<b>Process Instance</b>	F98860
<b>Activity Instance</b>	F98865



## Appendix B – System Functions

---

This appendix provides you with a brief overview of:

- Message system functions
- Workflow system functions

Refer to the system function documentation in the Online API guide for more information about these system functions.

### Message System Functions

Message system functions include the following:

<b>SendMessage</b>	Sends a message through the OneWorld mail system
<b>Update Message</b>	Modifies information associated with a message that has already been added using SendMessage
<b>ForwardMessage</b>	Forwards a OneWorld message automatically using a system function
<b>DeleteMessage</b>	Removes a message which was created using SendMessage
<b>TemplateSubstitution</b>	Allows the user to fill the message template with the substitution values and then receive the completed message template back in a text string. The output string can be displayed on the screen or printed on a report as generic text.

### Workflow System Functions

Workflow system functions include the following:

<b>GetActivityInstanceForKey</b>	Retrieves the active Workflow activity instance information for a given key
<b>CompleteActivity</b>	Completes an activity instance
<b>GetProcessInstanceAttributes</b>	Retrieves the key and attribute data structures for a given process instance
<b>GetProcessInstanceForKey</b>	Retrieves the Workflow process instance for a given key
<b>UpdateProcessInstanceAttributes</b>	Updates the attributes for a given process instance
<b>UpdateProcessInstanceAttributeSingle</b>	Updates a single process attribute for a given process instance
<b>StartProcess</b>	Starts a workflow process

## Appendix C – Distribution List Scenarios

---

This appendix includes several scenarios that illustrate how Workflow processes proceed through workflow activities for single-level and multiple-level distribution lists. These scenarios follow the same Credit Limit example that is used throughout this manual. Each scenario includes the setup used for a specific workflow process and the results that occur when that setup is used.

### Before You Begin

- Before you read the distribution list scenarios in this appendix, you should understand creating workflow processes. For more information, see *Creating Workflow Processes*.

### Reviewing Distribution List Guidelines

Depending on how you set up distribution lists and threshold values, situations might arise where an action message is not sent to any member of a distribution list. In these situations, you must ensure that a process instance can complete successfully. When an action message is not sent, the activity conditions surrounding that action message must have a default value that allows the workflow to continue. When you start a process, you can default in a value for the data item that your activity conditions use for comparison.

If the originator is in the distribution list, messages will not be sent to people in a lower group no matter what the threshold values are.

For multi-level distribution lists, if the originator is not in the list, the process will end in error.

### Single-Level Distribution Lists

#### Scenario: 1 Single-Level Distribution List

This scenario uses a single-level distribution list. The originator of the process is not included in the distribution list.

**Setup**

The information below illustrates a typical distribution list setup for the Credit Limit example.

A/B #	Description	Group #	Threshold Value
7101	Clerk #1	1	5000
7102	Clerk #2	1	5000
7103	Clerk #3	1	10000
7201	Manager #1	2	10000
7202	Manager #2	2	15000
7203	Manager #3	2	20000
7301	Director #1	3	20000
7302	Director #2	3	25000
7303	Director #3	3	25000
7401	VP #1	4	30000
7402	VP #2	4	30000
7501	President	5	31000

**Results**

The following results illustrate to which A/B numbers that messages would be passed. The value passed is the dollar amount used to determine which address book numbers receive the message. The address book numbers to the right are the result.

Value Passed												
4500	Not sent to list											
9500	7101	7102										
14500	7101	7102	7103	7201								
19500	7101	7102	7103	7201	7202							
24500	7101	7102	7103	7201	7202	7203	7301					
29500	7101	7102	7103	7201	7202	7203	7301	7302	7303			
30500	7101	7102	7103	7201	7202	7203	7301	7302	7303	7401	7402	
31500	7101	7102	7103	7201	7202	7203	7301	7302	7303	7401	7402	7501

**Scenario 2: Single-Level Distribution List**

In this scenario, the same setup is used as in Scenario 1, except that all threshold values are 0. The originator is not in the distribution list.

**Setup**

A/B #	Description	Group #	Threshold Value
7101	Clerk #1	1	0
7102	Clerk #2	1	0
7103	Clerk #3	1	0
7201	Manager #1	2	0
7202	Manager #2	2	0
7203	Manager #3	2	0
7301	Director #1	3	0
7302	Director #2	3	0
7303	Director #3	3	0
7401	VP #1	4	0
7402	VP #2	4	0
7501	President	5	0

**Results**

No matter what value is passed, the process goes through the entire distribution structure. Every A/B number gets a message.

**Scenario 3: Single-Level Distribution List**

This scenario uses a single-level distribution list. The originator of the workflow is not included in the distribution list.

**Setup**

Each group level in the distribution list is set to 1. A threshold value of 100 is used for each person.

Group	Name	Threshold Value
1	Tom	100
1	Barb	100
1	Tim	100
1	Dan	100

**Results**

Every A/B number is given a message if the amount sent is greater than the threshold.

Data Value	Sent to All #'s in Group
90	Did Not Send
110	Yes

## Multiple-Level Distribution Lists

### Scenario 4: Multiple-Level Distribution List

This scenario uses a multiple-level distribution list with threshold values. The originator is in the distribution list. If the originator is not in the multiple-level distribution list, the workflow fails.

#### Setup

All group levels are group 1 and threshold values are denoted in parentheses. The originator is 7101.

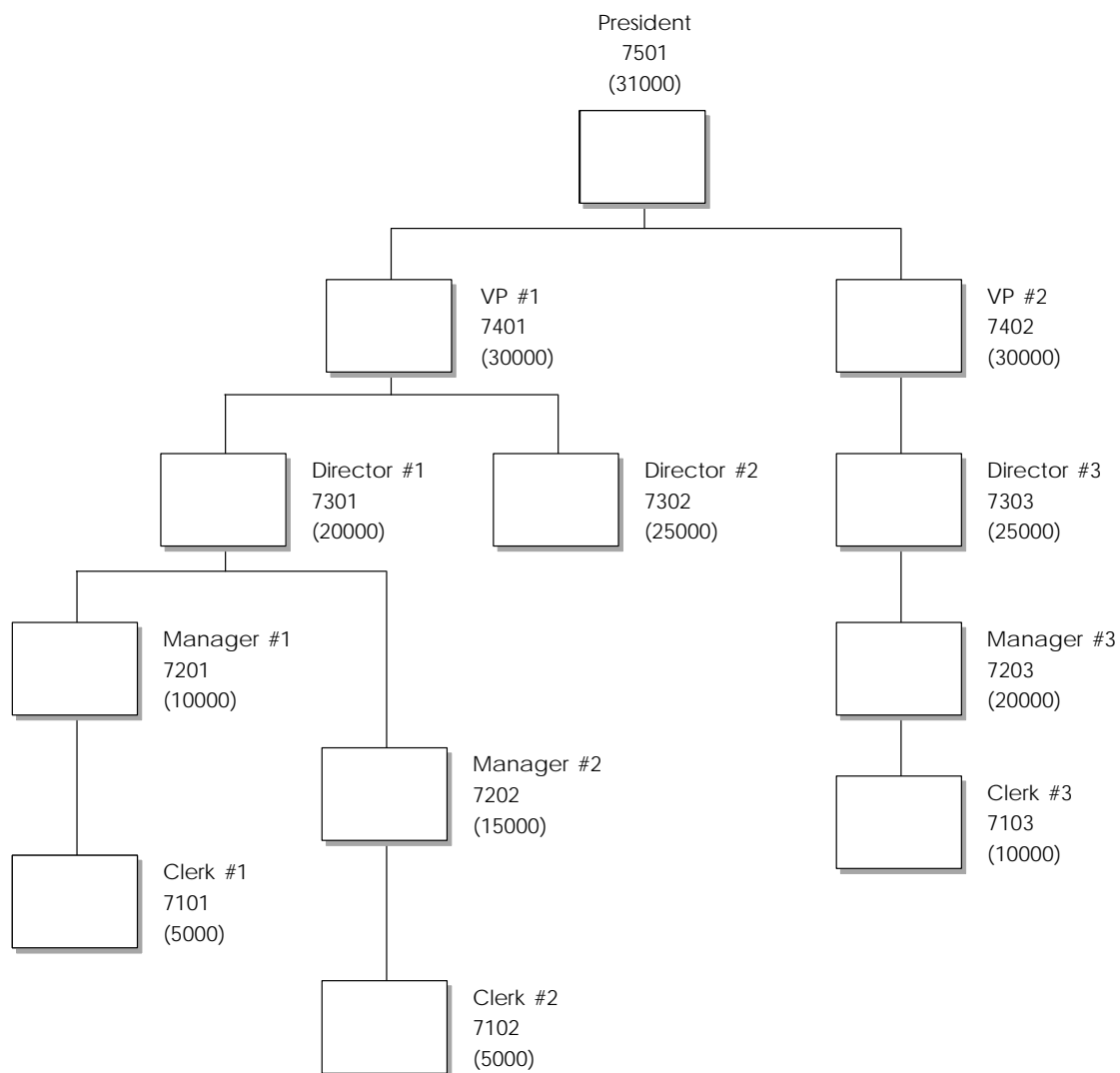

**Results**

If the value passed is lower than the originator or the originator’s manager’s threshold, the workflow will not send the action message. To prevent this situation, set a default value for the action messages that are not sent. For the Credit Limit scenario, you would probably accept the value passed amount because it is not a significant amount.

<b>Value Passed</b>				
4500	Not sent to list			
9500	Not sent to list			
14500	7201			
19500	7201			
24500	7201	7301		
29500	7201	7301		
30500	7201	7301	7401	
31500	7201	7301	7401	7501

**Scenario 5: Multiple-Level Distribution List**

This scenario uses a multiple-level distribution list with threshold values all set to 0. The originator is in the distribution list.

**Setup**

The originator is Clerk #1.

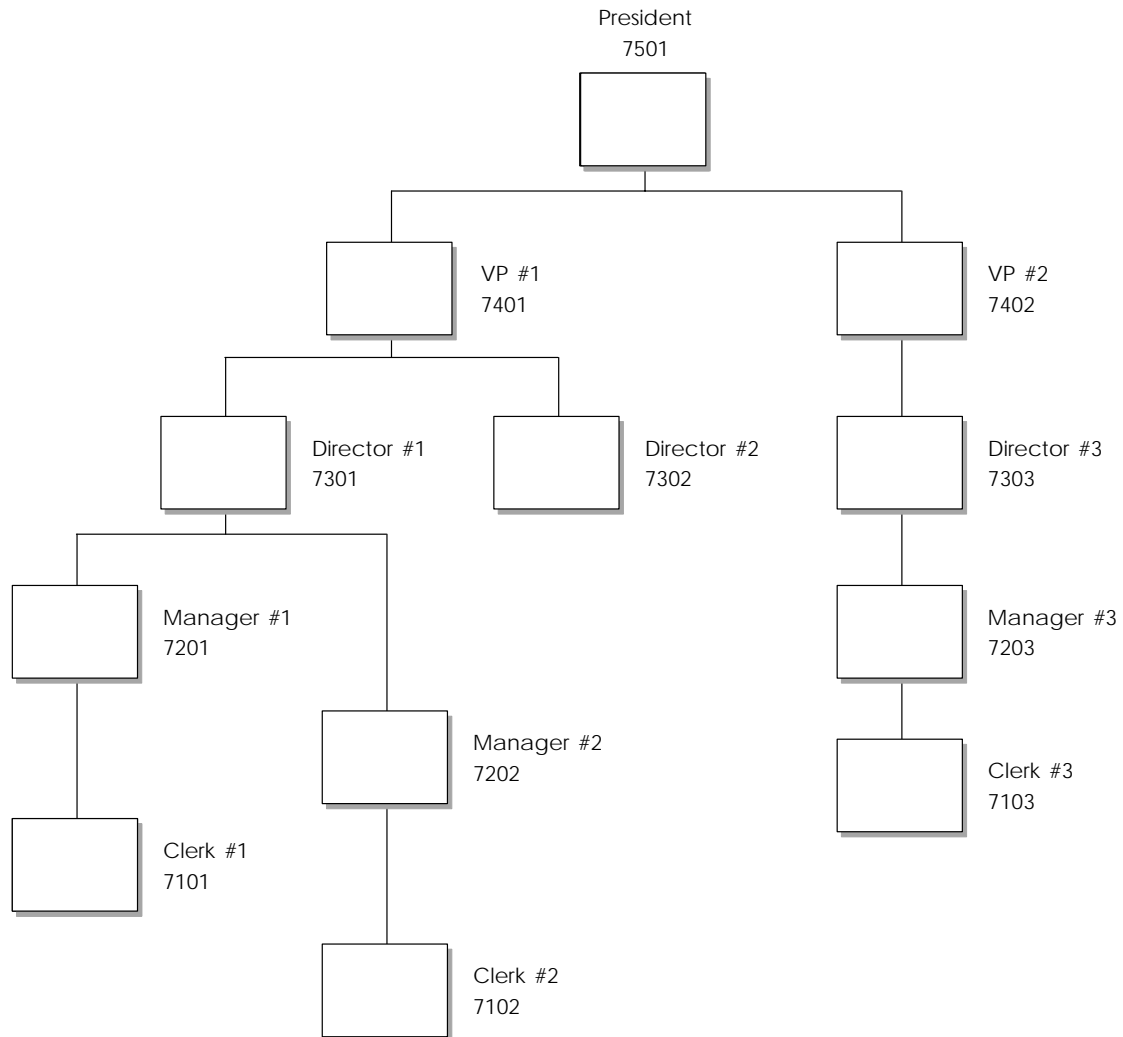

**Results**

Since there are no threshold values, everyone is sent the message.

Value Passed				
4500	7201	7301	7401	7501
9500	7201	7301	7401	7501
14500	<b>7201</b>	7301	7401	7501
19500	7201	7301	7401	7501
24500	7201	7301	7401	7501
29500	7201	7301	7401	7501
30500	7201	7301	7401	7501
31500	7201	7301	7401	7501

## Scenario 6

This scenario uses the same setup as Scenario 1. It uses a single level distribution list and the originator of the process is not included in the distribution list. This scenario shows the first response checked in a Single-Level Distribution List setup.

### Setup

A/B #	Description	Group #	Threshold Value
7101	Clerk #1	1	5000
7102	Clerk #2	1	5000
7103	Clerk #3	1	10000
7201	Manager #1	2	10000
7202	Manager #2	2	15000
7203	Manager #3	2	20000
7301	Director #1	3	20000
7302	Director #2	3	25000
7303	Director #3	3	25000
7401	VP #1	4	30000
7402	VP #2	4	30000
7501	President	5	31000

### Results

At a specific group level, the first individual to respond dictates how the process continues. For example, the response may tell the process to end the activity or to move on to the next higher group level in the distribution list.

The first response is not necessary in a multiple-level distribution list. If you have a situation where a clerk has two managers directly above him or her, both managers receive the message. The first manager to respond dictates how the process proceeds.

## Scenario 7: Higher Level Override Single-Level Distribution List

This scenario shows higher level overrides in a single level distribution list with threshold values. The originator is in the distribution list.

### Setup

The following setup uses Clerk #1 (A/B# 7101) as the originator. The value passed in is 31500.

<b>A/B #</b>	<b>Description</b>	<b>Group #</b>	<b>Threshold Value</b>
7101	Clerk #1	1	5000
7102	Clerk #2	1	5000
7103	Clerk #3	1	10000
7201	Manager #1	2	10000
7202	Manager #2	2	15000
7203	Manager #3	2	20000
7301	Director #1	3	20000
7302	Director #2	3	25000
7303	Director #3	3	25000
7401	VP 1	4	30000
7402	VP 2	4	30000
7501	President	5	31000

### Results

All A/B numbers above Group #1 show up in Process Activity Monitor in an awaiting status except for Manager #1 and Manager #2, which show an unopened status.

When this process is run, a user of higher group number can come in and override the workflow process to continue to the next activity. For example, in this scenario, if you sign into OneWorld as President and do a higher level override on Clerk #1, all A/B users display as bypassed, and the process ends as expected.

### Scenario 8: Higher Level Override Multiple-Level List

This scenario checks higher level overrides in a multiple-level distribution list with threshold values. The originator is in the distribution list.

#### Higher Level Overrides Multiple-Level List Setup

All group levels are Group #1 and threshold values are in parentheses. The originator is Clerk #1. The value passed in by the workflow is 31500.

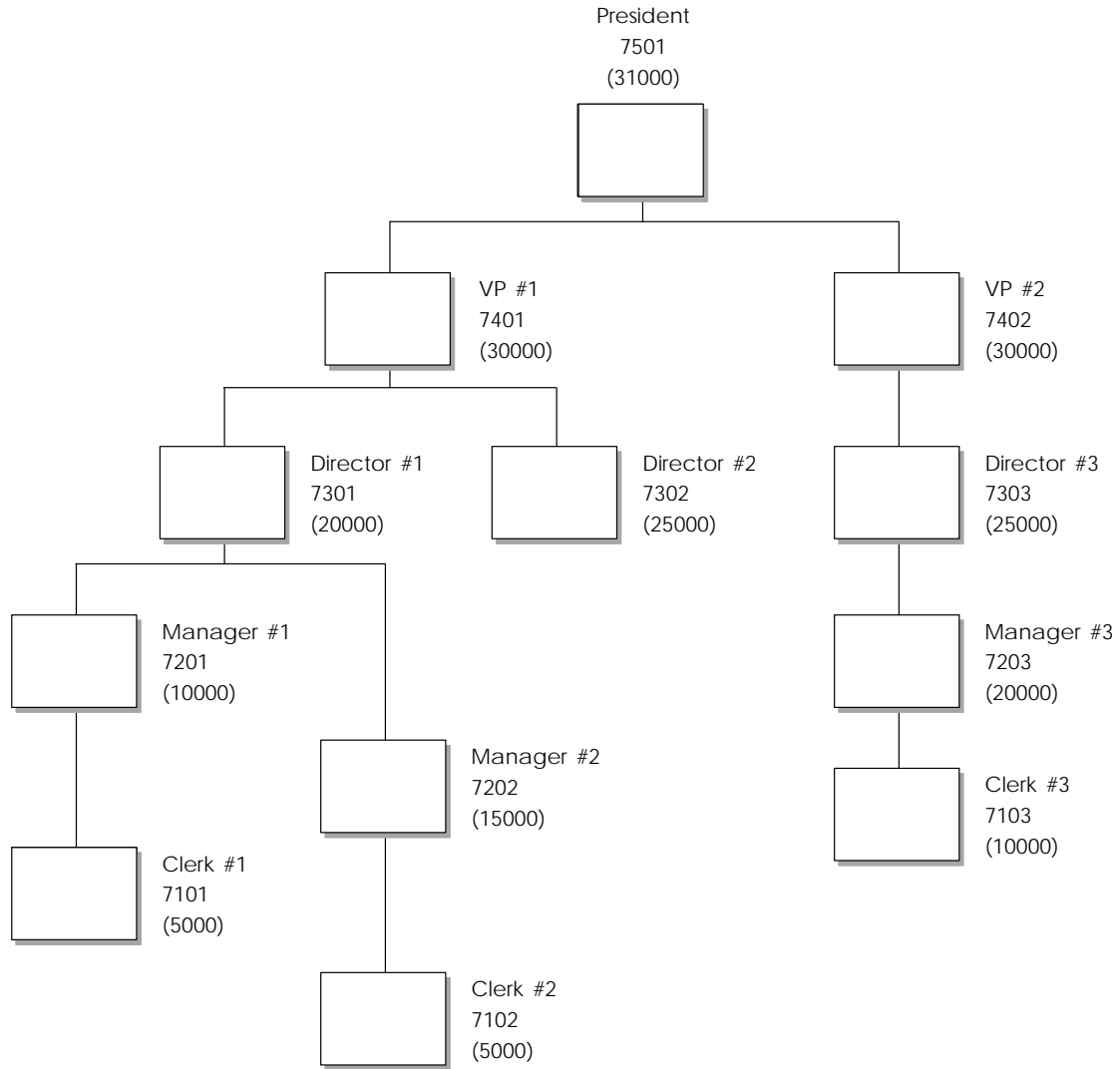

**Results**

All A/B numbers show up in the Process Activity Monitor in an awaiting status except for Manager #1, shows in an unopened status.

When this process is run, a user of higher group number can override the workflow process to continue to the next activity. For example, in this scenario, if you sign into OneWorld as President and do a higher level override on Manager #1, all A/B users display as bypassed, and the process ends as expected.



# Glossary



# Glossary

---

**AAI.** See automatic accounting instruction.

**action message.** With OneWorld, users can receive messages (system-generated or user-generated) that have shortcuts to OneWorld forms, applications, and appropriate data. For example, if the general ledger post sends an action error message to a user, that user can access the journal entry (or entries) in error directly from the message. This is a central feature of the OneWorld workflow strategy. Action messages can originate either from OneWorld or from a third-party e-mail system.

**activator.** In the Solution Explorer, a parent task with sequentially-arranged child tasks that are automated with a director.

**ActiveX.** A computing technology, based on object linking and embedding, that enables Java applet-style functionality for Web browsers as well as other applications. (Java is limited to Web browsers at this time.) The ActiveX equivalent of a Java applet is an ActiveX control. These controls bring computational, communications, and data manipulation power to programs that can “contain” them. For example, certain Web browsers, Microsoft Office programs, and anything developed with Visual Basic or Visual C++.

**advance.** A change in the status of a project in the Object Management Workbench. When you advance a project, the status change might trigger other actions and conditions such as moving objects from one server to another or preventing check-out of project objects.

**alphanumeric character.** A combination of letters, numbers, and symbols used to represent data. Contrast with numeric character and special character.

**API.** See application programming interface.

**APPL.** See application.

**applet.** A small application, such as a utility program or a limited-function spreadsheet. It is generally associated with the programming language Java, and in this context refers to

Internet-enabled applications that can be passed from a Web browser residing on a workstation.

**application.** In the computer industry, the same as an executable file. In OneWorld, an interactive or batch application is a DLL that contains programming for a set of related forms that can be run from a menu to perform a business task such as Accounts Payable and Sales Order Processing. Also known as system.

**application developer.** A programmer who develops OneWorld applications using the OneWorld toolset.

**application programming interface (API).** A software function call that can be made from a program to access functionality provided by another program.

**application workspace.** The area on a workstation display in which all related forms within an application appear.

**audit trail.** The detailed, verifiable history of a processed transaction. The history consists of the original documents, transaction entries, and posting of records, and usually concludes with a report.

**automatic accounting instruction (AAI).** A code that refers to an account in the chart of accounts. AAIs define rules for programs that automatically generate journal entries, including interfaces between Accounts Payable, Accounts Receivable, Financial Reporting, General Accounting systems. Each system that interfaces with the General Accounting system has AAIs. For example, AAIs can direct the General Ledger Post program to post a debit to a specific expense account and a credit to a specific accounts payable account.

**batch header.** The information that identifies and controls a batch of transactions or records.

**batch job.** A task or group of tasks you submit for processing that the system treats as a single unit during processing, for example, printing reports and purging files. The computer system

performs a batch job with little or no user interaction.

**batch processing.** A method by which the system selects jobs from the job queue, processes them, and sends output to the outqueue. Contrast with interactive processing.

**batch server.** A server on which OneWorld batch processing requests (also called UBEs) are run instead of on a client, an application server, or an enterprise server. A batch server typically does not contain a database nor does it run interactive applications.

**batch type.** A code assigned to a batch job that designates to which J.D. Edwards system the associated transactions pertain, thus controlling which records are selected for processing. For example, the Post General Journal program selects for posting only unposted transaction batches with a batch type of O.

**batch-of-one immediate.** A transaction method that allows a client application to perform work on a client workstation, then submit the work all at once to a server application for further processing. As a batch process is running on the server, the client application can continue performing other tasks. See also direct connect, store and forward.

**BDA.** See Business View Design Aid.

**binary string (BSTR).** A length prefixed string used by OLE automation data manipulation functions. Binary Strings are wide, double-byte (Unicode) strings on 32-bit Windows platforms.

**Boolean Logic Operand.** In J.D. Edwards reporting programs, the parameter of the Relationship field. The Boolean logic operand instructs the system to compare certain records or parameters. Available options are:

- EQ Equal To.
- LT Less Than.
- LE Less Than or Equal To.
- GT Greater Than.
- GE Greater Than or Equal To.
- NE Not Equal To.
- NL Not Less Than.
- NG Not Greater Than.

**browser.** A client application that translates information sent by the World Wide Web. A client must use a browser to receive, manipulate, and display World Wide Web

information on the desktop. Also known as a Web browser.

**BSFN.** See business function.

**BSTR.** See binary string.

**BSVW.** See business view.

**business function.** An encapsulated set of business rules and logic that can normally be reused by multiple applications. Business functions can execute a transaction or a subset of a transaction (check inventory, issue work orders, and so on). Business functions also contain the APIs that allow them to be called from a form, a database trigger, or a non-OneWorld application. Business functions can be combined with other business functions, forms, event rules, and other components to make up an application. Business functions can be created through event rules or third-generation languages, such as C. Examples of business functions include Credit Check and Item Availability.

**business function event rule.** See named event rule.

**business view.** Used by OneWorld applications to access data from database tables. A business view is a means for selecting specific columns from one or more tables whose data will be used in an application or report. It does not select specific rows and does not contain any physical data. It is strictly a view through which data can be handled.

**Business View Design Aid (BDA).** A OneWorld GUI tool for creating, modifying, copying, and printing business views. The tool uses a graphical user interface.

**category code.** In user defined codes, a temporary title for an undefined category. For example, if you are adding a code that designates different sales regions, you could change category code 4 to Sales Region, and define E (East), W (West), N (North), and S (South) as the valid codes. Sometimes referred to as reporting codes.

**central objects.** Objects that reside in a central location and consist of two parts: the central objects data source and central C components. The central objects data source contains OneWorld specifications, which are stored in a relational database. Central C components

contain business function source, header, object, library, and DLL files and are usually stored in directories on the deployment server. Together they make up central objects.

**check-in location.** The directory structure location for the package and its set of replicated objects. This is usually \\deploymentserver\release\path\_code\package\packagename. The sub-directories under this path are where the central C components (source, include, object, library, and DLL file) for business functions are stored.

**child.** See parent/child form.

**client/server.** A relationship between processes running on separate machines. The server process is a provider of software services. The client is a consumer of those services. In essence, client/server provides a clean separation of function based on the idea of service. A server can service many clients at the same time and regulate their access to shared resources. There is a many-to-one relationship between clients and a server, respectively. Clients always initiate the dialog by requesting a service. Servers passively wait for requests from clients.

**CNC.** See configurable network computing.

**component.** In the ActivEra Portal, an encapsulated object that appears inside a workspace. Portal components

**configurable client engine.** Allows user flexibility at the interface level. Users can easily move columns, set tabs for different data views, and size grids according to their needs. The configurable client engine also enables the incorporation of Web browsers in addition to the Windows 95- and Windows NT-based interfaces.

**configurable network computing.** An application architecture that allows interactive and batch applications, composed of a single code base, to run across a TCP/IP network of multiple server platforms and SQL databases. The applications consist of reusable business functions and associated data that can be configured across the network dynamically. The overall objective for businesses is to provide a future-proof environment that enables them to change organizational structures, business

processes, and technologies independently of each other.

**constants.** Parameters or codes that you set and the system uses to standardize information processing by associated programs. Some examples of constants are: validating bills of material online and including fixed labor overhead in costing.

**control.** Any data entry point allowing the user to interact with an application. For example, check boxes, pull-down lists, hyper-buttons, entry fields, and similar features are controls.

**core.** The central and foundation systems of J.D. Edwards software, including General Accounting, Accounts Payable, Accounts Receivable, Address Book, Financial Reporting, Financial Modeling and Allocations, and Back Office.

**CRP.** Conference Room Pilot.

**custom gridlines.** A grid row that does not come from the database, for example, totals. To display a total in a grid, sum the values and insert a custom gridline to display the total. Use the system function Insert Grid Row Buffer to accomplish this.

**data dictionary.** The OneWorld method for storing and managing data item definitions and specifications. J.D. Edwards has an active data dictionary, which means it is accessed at runtime.

**data mart.** Department-level decision support databases. They usually draw their data from an enterprise data warehouse that serves as a source of consolidated and reconciled data from around the organization. Data marts can be either relational or multidimensional databases.

**data replication.** In a replicated environment, multiple copies of data are maintained on multiple machines. There must be a single source that "owns" the data. This ensures that the latest copy of data can be applied to a primary place and then replicated as appropriate. This is in contrast to a simple copying of data, where the copy is not maintained from a central location, but exists independently of the source.

**data source.** A specific instance of a database management system running on a computer. Data source management is accomplished

through Object Configuration Manager (OCM) and Object Map (OM).

**data structure.** A group of data items that can be used for passing information between objects, for example, between two forms, between forms and business functions, or between reports and business functions.

**data warehouse.** A database used for reconciling and consolidating data from multiple databases before it is distributed to data marts for department-level decision support queries and reports. The data warehouse is generally a large relational database residing on a dedicated server between operational databases and the data marts.

**data warehousing.** Essentially, data warehousing involves off-loading operational data sources to target databases that will be used exclusively for decision support (reports and queries). There are a range of decision support environments, including duplicated database, enhanced analysis databases, and enterprise data warehouses.

**database.** A continuously updated collection of all information a system uses and stores. Databases make it possible to create, store, index, and cross-reference information online.

**database driver.** Software that connects an application to a specific database management system.

**database server.** A server that stores data. A database server does not have OneWorld logic.

**DCE.** See distributed computing environment.

**DD.** See data dictionary.

**default.** A code, number, or parameter value that is assumed when none is specified.

**detail.** The specific pieces of information and data that make up a record or transaction. Contrast with summary.

**detail area.** A control that is found in OneWorld applications and functions similarly to a spreadsheet grid for viewing, adding, or updating many rows of data at one time.

**direct connect.** A transaction method in which a client application communicates interactively and directly with a server application. See also batch-of-one immediate, store and forward.

**director.** An interactive utility that guides a user through the steps of a process to complete a task.

**distributed computing environment (DCE).** A set of integrated software services that allows software running on multiple computers to perform in a manner that is seamless and transparent to the end-users. DCE provides security, directory, time, remote procedure calls, and files across computers running on a network.

**DLL.** See dynamic link library.

**DS.** See data structure.

**DSTR.** See data structure.

**duplicated database.** A decision support database that contains a straightforward copy of operational data. The advantages involve improved performance for both operational and reporting environments. See also enhanced analysis database, enterprise data warehouse.

**dynamic link library (DLL).** A set of program modules that are designed to be invoked from executable files when the executable files are run, without having to be linked to the executable files. They typically contain commonly used functions.

**dynamic partitioning.** The ability to dynamically distribute logic or data to multiple tiers in a client/server architecture.

**embedded event rule.** An event rule that is specific to a particular table or application. Examples include form-to-form calls, hiding a field based on a processing option value, and calling a business function. Contrast with business function event rule. See also event rule.

**employee work center.** This is a central location for sending and receiving all OneWorld messages (system and user generated) regardless of the originating application or user. Each user has a mailbox that contains workflow and other messages, including Active Messages. With respect to workflow, the Message Center is MAPI compliant and supports drag and drop work reassignment, escalation, forward and reply, and workflow monitoring. All messages from the message center can be viewed through OneWorld messages or Microsoft Exchange.

**encapsulation.** The ability to confine access to and manipulation of data within an object to the

procedures that contribute to the definition of that object.

**enhanced analysis database.** A database containing a subset of operational data. The data on the enhanced analysis database performs calculations and provides summary data to speed generation of reports and query response times. This solution is appropriate when external data must be added to source data, or when historical data is necessary for trend analysis or regulatory reporting. See also duplicated database, enterprise data warehouse.

**enterprise data warehouse.** A complex solution that involves data from many areas of the enterprise. This environment requires a large relational database (the data warehouse) that is a central repository of enterprise data, which is clean, reconciled, and consolidated. From this repository, data marts retrieve data to provide department-level decisions. See also duplicated database, enhanced analysis database.

**enterprise server.** A database server and logic server. See database server. Also referred to as host.

**ER.** See event rule.

**ERP.** See enterprise resource planning.

**event.** An action that occurs when an interactive or batch application is running. Example events are tabbing out of an edit control, clicking a push button, initializing a form, or performing a page break on a report. The GUI operating system uses miniprograms to manage user activities within a form. Additional logic can be attached to these miniprograms and used to give greater functionality to any event within a OneWorld application or report using event rules.

**event rule.** Used to create complex business logic without the difficult syntax that comes with many programming languages. These logic statements can be attached to applications or database events and are executed when the defined event occurs, such as entering a form, selecting a menu bar option, page breaking on a report, or selecting a record. An event rule can validate data, send a message to a user, call a business function, as well as many other actions. There are two types of event rules:

- 1 Embedded event rules.
- 2 Named event rules.

**executable file.** A computer program that can be run from the computer's operating system. Equivalent terms are "application" and "program."

**exit.** 1) To interrupt or leave a computer program by pressing a specific key or a sequence of keys. 2) An option or function key displayed on a form that allows you to access another form.

**facility.** 1) A separate entity within a business for which you want to track costs. For example, a facility might be a warehouse location, job, project, work center, or branch/plant. Sometimes referred to as a business unit. 2) In Home Builder and ECS, a facility is a collection of computer language statements or programs that provide a specialized function throughout a system or throughout all integrated systems. For example, DREAM Writer and FASTR are facilities.

**FDA.** See Form Design Aid.

**find/browse.** A type of form used to:

- 1 Search, view, and select multiple records in a detail area.
- 2 Delete records.
- 3 Exit to another form.
- 4 Serve as an entry point for most applications.

**firewall.** A set of technologies that allows an enterprise to test, filter, and route all incoming messages. Firewalls are used to keep an enterprise secure.

**fix/inspect.** A type of form used to view, add, or modify existing records. A fix/inspect form has no detail area.

**form.** An element of OneWorld's graphical user interface that contains controls by which a user can interact with an application. Forms allow the user to input, select, and view information. A OneWorld application might contain multiple forms. In Microsoft Windows terminology, a form is known as a dialog box.

**Form Design Aid (FDA).** The OneWorld GUI development tool for building interactive applications and forms.

**form interconnection.** Allows one form to access and pass data to another form. Form interconnections can be attached to any event; however, they are normally used when a button is clicked.

**form type.** The following form types are available in OneWorld:

- 1 Find/browse.
- 2 Fix/inspect.
- 3 Header detail.
- 4 Headerless detail.
- 5 Message.
- 6 Parent/child.
- 7 Search/select.

**fourth generation language (4GL).** A programming language that focuses on what you need to do and then determines how to do it. Structured Query Language is an example of a 4GL.

**graphical user interface (GUI).** A computer interface that is graphically based as opposed to being character-based. An example of a character-based interface is that of the AS/400. An example of a GUI is Microsoft Windows. Graphically based interfaces allow pictures and other graphic images to be used in order to give people clues on how to operate the computer.

**grid.** See detail area.

**GUI.** See graphical user interface.

**header.** Information at the beginning of a table or form. This information is used to identify or provide control information for the group of records that follows.

**header/detail.** A type of form used to add, modify, or delete records from two different tables. The tables usually have a parent/child relationship.

**headerless detail.** A type of form used to work with multiple records in a detail area. The detail area is capable of receiving input.

**hidden selections.** Menu selections you cannot see until you enter HS in a menu's Selection field. Although you cannot see these selections, they are available from any menu. They include such items as Display Submitted Jobs (33), Display User Job Queue (42), and Display User Print Queue (43). The Hidden Selections window displays three categories of selections: user tools, operator tools, and programmer tools.

**host.** In the centralized computer model, a large timesharing computer system that terminals communicate with and rely on for processing. In contrast with client/server in that those users

work at computers that perform much of their own processing and access servers that provide services such as file management, security, and printer management.

**HTML.** See hypertext markup language.

**hypertext markup language.** A markup language used to specify the logical structure of a document rather than the physical layout. Specifying logical structure makes any HTML document platform independent. You can view an HTML document on any desktop capable of supporting a browser. HTML can include active links to other HTML documents anywhere on the Internet or on intranet sites.

**index.** Represents both an ordering of values and a uniqueness of values that provide efficient access to data in rows of a table. An index is made up of one or more columns in the table.

**inheritance.** The ability of a class to receive all or parts of the data and procedure definitions from a parent class. Inheritance enhances development through the reuse of classes and their related code.

**install system code.** See system code.

**integrated toolset.** Unique to OneWorld is an industrial-strength toolset embedded in the already comprehensive business applications. This toolset is the same toolset used by J.D. Edwards to build OneWorld interactive and batch applications. Much more than a development environment, however, the OneWorld integrated toolset handles reporting and other batch processes, change management, and basic data warehousing facilities.

**interactive processing.** Processing actions that occur in response to commands you enter directly into the system. During interactive processing, you are in direct communication with the system, and it might prompt you for additional information while processing your request. See also online. Contrast with batch processing.

**interface.** A link between two or more computer systems that allows these systems to send information to and receive information from one another.

**Internet.** The worldwide constellation of servers, applications, and information available

to a desktop client through a phone line or other type of remote access.

**interoperability.** The ability of different computer systems, networks, operating systems, and applications to work together and share information.

**intranet.** A small version of the Internet usually confined to one company or organization. An intranet uses the functionality of the Internet and places it at the disposal of a single enterprise.

**IP.** A connection-less communication protocol that by itself provides a datagram service. Datagrams are self-contained packets of information that are forwarded by routers based on their address and the routing table information contained in the routers. Every node on a TCP/IP network requires an address that identifies both a network and a local host or node on the network. In most cases the network administrator sets up these addresses when installing new workstations. In some cases, however, it is possible for a workstation, when booting up, to query a server for a dynamically assigned address.

**IServer Service.** Developed by J.D. Edwards, this internet server service resides on the web server, and is used to speed up delivery of the Java class files from the database to the client.

**ISO 9000.** A series of standards established by the International Organization for Standardization, designed as a measure of product and service quality.

**J.D. Edwards Database.** See JDEBASE Database Middleware.

**Java.** An Internet executable language that, like C, is designed to be highly portable across platforms. This programming language was developed by Sun Microsystems. Applets, or Java applications, can be accessed from a web browser and executed at the client, provided that the operating system or browser is Java-enabled. (Java is often described as a scaled-down C++). Java applications are platform independent.

**Java Database Connectivity (JDBC).** The standard way to access Java databases, set by Sun Microsystems. This standard allows you to use any JDBC driver database.

**JavaScript.** A scripting language related to Java. Unlike Java, however, JavaScript is not an object-oriented language and it is not compiled.

**jde.ini.** J.D. Edwards file (or member for AS/400) that provides the runtime settings required for OneWorld initialization. Specific versions of the file/member must reside on every machine running OneWorld. This includes workstations and servers.

**JDEBASE Database Middleware.** J.D. Edwards proprietary database middleware package that provides two primary benefits:

1. Platform-independent APIs for multidatabase access. These APIs are used in two ways:
  - a. By the interactive and batch engines to dynamically generate platform-specific SQL, depending on the datasource request.
  - b. As open APIs for advanced C business function writing. These APIs are then used by the engines to dynamically generate platform-specific SQL.
2. Client-to-server and server-to-server database access. To accomplish this OneWorld is integrated with a variety of third-party database drivers, such as Client Access 400 and open database connectivity (ODBC).

**JDECallObject.** An application programming interface used by business functions to invoke other business functions.

**JDENET.** J.D. Edwards proprietary middleware software. JDENET is a messaging software package.

**JDENET communications middleware.** J.D. Edwards proprietary communications middleware package for OneWorld. It is a peer-to-peer, message-based, socket based, multiprocess communications middleware solution. It handles client-to-server and server-to-server communications for all OneWorld supported platforms.

**job queue.** A group of jobs waiting to be batch processed. See also batch processing.

**just in time installation (JITI).** OneWorld's method of dynamically replicating objects from the central object location to a workstation.

**just in time replication (JITR).** OneWorld's method of replicating data to individual

workstations. OneWorld replicates new records (inserts) only at the time the user needs the data. Changes, deletes, and updates must be replicated using Pull Replication.

**KEY.** A column or combination of columns that identify one or more records in a database table.

**leading zeros.** A series of zeros that certain facilities in J.D. Edwards systems place in front of a value you enter. This normally occurs when you enter a value that is smaller than the specified length of the field. For example, if you enter 4567 in a field that accommodates eight numbers, the facility places four zeros in front of the four numbers you enter. The result appears as: 00004567.

**level of detail.** 1) The degree of difficulty of a menu in J.D. Edwards software. The levels of detail for menus are as follows:

- A Major Product Directories.
- B Product Groups.
- 1 Basic Operations.
- 2 Intermediate Operations.
- 3 Advanced Operations.
- 4 Computer Operations.
- 5 Programmers.
- 6 Advanced Programmers Also known as menu levels.

2) The degree to which account information in the General Accounting system is summarized. The highest level of detail is 1 (least detailed) and the lowest level of detail is 9 (most detailed).

**MAPI.** See Messaging Application Programming Interface.

**master table.** A database table used to store data and information that is permanent and necessary to the system's operation. Master tables might contain data such as paid tax amounts, supplier names, addresses, employee information, and job information.

**menu.** A menu that displays numbered selections. Each of these selections represents a program or another menu. To access a selection from a menu, type the selection number and then press Enter.

**menu levels.** See level of detail.

**menu masking.** A security feature of J.D. Edwards systems that lets you prevent individual users from accessing specified menus or menu

selections. The system does not display the menus or menu selections to unauthorized users.

**Messaging Application Programming Interface (MAPI).** An architecture that defines the components of a messaging system and how they behave. It also defines the interface between the messaging system and the components.

**middleware.** A general term that covers all the distributed software needed to support interactions between clients and servers. Think of it as the software that's in the middle of the client/server system or the "glue" that lets the client obtain a service from a server.

**modal.** A restrictive or limiting interaction created by a given condition of operation. Modal often describes a secondary window that restricts a user's interaction with other windows. A secondary window can be modal with respect to its primary window or to the entire system. A modal dialog box must be closed by the user before the application continues.

**mode.** In reference to forms in OneWorld, mode has two meanings:

- An operational qualifier that governs how the form interacts with tables and business views. OneWorld form modes are: add, copy, and update.
- An arbitrary setting that aids in organizing form generation for different environments. For example, you might set forms generated for a Windows environment to mode 1 and forms generated for a Web environment to mode 2.

**modeless.** Not restricting or limiting interaction. Modeless often describes a secondary window that does not restrict a user's interaction with other windows. A modeless dialog box stays on the screen and is available for use at any time but also permits other user activities.

**multitier architecture.** A client/server architecture that allows multiple levels of processing. A tier defines the number of computers that can be used to complete some defined task.

**named event rule.** Encapsulated, reusable business logic created using through event rules rather than C programming. Contrast with embedded event rule. See also event rule.

**NER.** See named event rule.

**network computer.** As opposed to the personal computer, the network computer offers (in theory) lower cost of purchase and ownership and less complexity. Basically, it is a scaled-down PC (very little memory or disk space) that can be used to access network-based applications (Java applets, ActiveX controls) via a network browser.

**network computing.** Often referred to as the next phase of computing after client/server. While its exact definition remains obscure, it generally encompasses issues such as transparent access to computing resources, browser-style front-ends, platform independence, and other similar concepts.

**next numbers.** A feature you use to control the automatic numbering of such items as new G/L accounts, vouchers, and addresses. It lets you specify a numbering system and provides a method to increment numbers to reduce transposition and typing errors.

**non-object librarian object.** An object that is not managed by the object librarian.

**numeric character.** Digits 0 through 9 that are used to represent data. Contrast with alphanumeric characters.

**object.** A self-sufficient entity that contains data as well as the structures and functions used to manipulate the data. For OneWorld purposes, an object is a reusable entity that is based on software specifications created by the OneWorld toolset. See also object librarian.

**object configuration manager (OCM).** OneWorld's Object Request Broker and the control center for the runtime environment. It keeps track of the runtime locations for business functions, data, and batch applications. When one of these objects is called, the Object Configuration Manager directs access to it using defaults and overrides for a given environment and user.

**object embedding.** When an object is embedded in another document, an association is maintained between the object and the application that created it; however, any changes made to the object are also only kept in the compound document. See also object linking.

**object librarian.** A repository of all versions, applications, and business functions reusable in building applications. You access these objects with the Object Management Workbench.

**object librarian object.** An object managed by the object librarian.

**object linking.** When an object is linked to another document, a reference is created with the file the object is stored in, as well as with the application that created it. When the object is modified, either from the compound document or directly through the file it is saved in, the change is reflected in that application as well as anywhere it has been linked. See also object embedding.

**object linking and embedding (OLE).** A way to integrate objects from diverse applications, such as graphics, charts, spreadsheets, text, or an audio clip from a sound program. See also object embedding, object linking.

**object management workbench (OMW).** An application that provides check-out and check-in capabilities for developers, and aids in the creation, modification, and use of OneWorld Objects. The OMW supports multiple environments (such as production and development).

**object-based technology (OBT).** A technology that supports some of the main principles of object-oriented technology: classes, polymorphism, inheritance, or encapsulation.

**object-oriented technology (OOT).** Brings software development past procedural programming into a world of reusable programming that simplifies development of applications. Object orientation is based on the following principles: classes, polymorphism, inheritance, and encapsulation.

**OCM.** See object configuration manager.

**ODBC.** See open database connectivity.

**OLE.** See object linking and embedding.

**OMW.** Object Management Workbench.

**OneWorld.** A combined suite of comprehensive, mission-critical business applications and an embedded toolset for configuring those applications to unique business and technology requirements. OneWorld is built on the Configurable Network

Computing technology- J.D. Edwards' own application architecture, which extends client/server functionality to new levels of configurability, adaptability, and stability.

**OneWorld application.** Interactive or batch processes that execute the business functionality of OneWorld. They consist of reusable business functions and associated data that are platform independent and can be dynamically configured across a TCP/IP network.

**OneWorld object.** A reusable piece of code that is used to build applications. Object types include tables, forms, business functions, data dictionary items, batch processes, business views, event rules, versions, data structures, and media objects. See also object.

**OneWorld process.** Allows OneWorld clients and servers to handle processing requests and execute transactions. A client runs one process, and servers can have multiple instances. OneWorld processes can also be dedicated to specific tasks (for example, workflow messages and data replication) to ensure that critical processes don't have to wait if the server is particularly busy.

**OneWorld Web development computer.** A standard OneWorld Windows developer computer with the additional components installed:

- JFC (0.5.1).
- Generator Package with Generator.Java and JDECOM.dll.
- R2 with interpretive and application controls/form.

**online.** Computer functions over which the system has continuous control. Users are online with the system when working with J.D. Edwards system provided forms.

**open database connectivity (ODBC).** Defines a standard interface for different technologies to process data between applications and different data sources. The ODBC interface is made up of a set of function calls, methods of connectivity, and representation of data types that define access to data sources.

**open systems interconnection (OSI).** The OSI model was developed by the International Standards Organization (ISO) in the early 1980s. It defines protocols and standards for the

interconnection of computers and network equipment.

**operand.** See Boolean Logic Operand.

**output.** Information that the computer transfers from internal storage to an external device, such as a printer or a computer form.

**output queue.** See print queue.

**package.** OneWorld objects are installed to workstations in packages from the deployment server. A package can be compared to a bill of material or kit that indicates the necessary objects for that workstation and where on the deployment server the install program can find them. It is a point-in-time "snap shot" of the central objects on the deployment server.

**package location.** The directory structure location for the package and its set of replicated objects. This is usually `\\deployment server\release\path_code\package\ package name`. The sub-directories under this path are where the replicated objects for the package will be placed. This is also referred to as where the package is built or stored.

**parameter.** A number, code, or character string you specify in association with a command or program. The computer uses parameters as additional input or to control the actions of the command or program.

**parent/child form.** A type of form that presents parent/child relationships in an application on one form. The left portion of the form presents a tree view that displays a visual representation of a parent/child relationship. The right portion of the form displays a detail area in browse mode. The detail area displays the records for the child item in the tree. The parent/child form supports drag and drop functionality.

**partitioning.** A technique for distributing data to local and remote sites to place data closer to the users who access. Portions of data can be copied to different database management systems.

**path code.** A pointer to a specific set of objects. A path code is used to locate:

1. Central Objects.
2. Replicated Objects.

**platform independence.** A benefit of open systems and Configurable Network Computing.

Applications that are composed of a single code base can be run across a TCP/IP network consisting of various server platforms and SQL databases.

**polymorphism.** A principle of object-oriented technology in which a single mnemonic name can be used to perform similar operations on software objects of different types.

**portability.** Allows the same application to run on different operating systems and hardware platforms.

**portal.** A configurable Web object that provides information and links to the Web. Portals can be used as home pages and are typically used in conjunction with a Web browser.

**primary key.** A column or combination of columns that uniquely identifies each row in a table.

**print queue.** A list of tables, such as reports, that you have submitted to be written to an output device, such as a printer. The computer spools the tables until it writes them. After the computer writes the table, the system removes the table identifier from the list.

**processing option.** A feature of the J.D. Edwards reporting system that allows you to supply parameters to direct the functions of a program. For example, processing options allow you to specify defaults for certain form displays, control the format in which information prints on reports, change how a form displays information, and enter beginning dates.

**program temporary fix (PTF).** A representation of changes to J.D. Edwards software that your organization receives on magnetic tapes or diskettes.

**project.** An Object Management Workbench object used to organize objects in development.

**published table.** Also called a “Master” table, this is the central copy to be replicated to other machines. Resides on the “Publisher” machine. the Data Replication Publisher Table (F98DRPUB) identifies all of the Published Tables and their associated Publishers in the enterprise.

**publisher.** The server that is responsible for the Published Table. The Data Replication Publisher Table (F98DRPUB) identifies all of the Published

Tables and their associated Publishers in the enterprise.

**pull replication.** One of the OneWorld methods for replicating data to individual workstations. Such machines are set up as Pull Subscribers using OneWorld’s data replication tools. The only time Pull Subscribers are notified of changes, updates, and deletions is when they request such information. The request is in the form of a message that is sent, usually at startup, from the Pull Subscriber to the server machine that stores the Data Replication Pending Change Notification table (F98DRPCN).

**purge.** The process of removing records or data from a system table.

**QBE.** See query by example.

**query by example (QBE).** Located at the top of a detail area, it is used to search for data to be displayed in the detail area.

**redundancy.** Storing exact copies of data in multiple databases.

**regenerable.** Source code for OneWorld business functions can be regenerated from specifications (business function names). Regeneration occurs whenever an application is recompiled, either for a new platform or when new functionality is added.

**relationship.** Links tables together and facilitates joining business views for use in an application or report. Relationships are created based on indexes.

**release/release update.** A “release” contains major new functionality, and a “release update” contains an accumulation of fixes and performance enhancements, but no new functionality.

**replicated object.** A copy or replicated set of the central objects must reside on each client and server that run OneWorld. The path code indicates the directory the directory where these objects are located.

**run.** To cause the computer system to perform a routine, process a batch of transactions, or carry out computer program instructions.

**SAR.** See software action request.

**scalability.** Allows software, architecture, network, or hardware growth that will support software as it grows in size or resource

requirements. The ability to reach higher levels of performance by adding microprocessors.

**search/select.** A type of form used to search for a value and return it to the calling field.

**selection.** Found on J.D. Edwards menus, selections represent functions that you can access from a menu. To make a selection, type the associated number in the Selection field and press Enter.

**server.** Provides the essential functions for furnishings services to network users (or clients) and provides management functions for network administrators. Some of these functions are storage of user programs and data and management functions for the file systems. It may not be possible for one server to support all users with the required services. Some examples of dedicated servers that handle specific tasks are backup and archive servers, application and database servers.

**servlet.** Servlets provide a Java-based solution used to address the problems currently associated with doing server-side programming, including inextensible scripting solutions. Servlets are objects that conform to a specific interface that can be plugged into a Java-based server. Servlets are to the server-side what applets are to the client-side.

**software.** The operating system and application programs that tell the computer how and what tasks to perform.

**software action request (SAR).** An entry in the AS/400 database used for requesting modifications to J.D. Edwards software.

**special character.** A symbol used to represent data. Some examples are \*, &, #, and /. Contrast with alphanumeric character and numeric character.

**specifications.** A complete description of a OneWorld object. Each object has its own specification, or name, which is used to build applications.

**Specs.** See specifications.

**spool.** The function by which the system stores generated output to await printing and processing.

**spooled table.** A holding file for output data waiting to be printed or input data waiting to be processed.

**SQL.** See structured query language.

**static text.** Short, descriptive text that appears next to a control variable or field. When the variable or field is enabled, the static text is black; when the variable or field is disabled, the static text is gray.

**store and forward.** A transaction method that allows a client application to perform work and, at a later time, complete that work by connecting to a server application. This often involves uploading data residing on a client to a server.

**structured query language (SQL).** A fourth generation language used as an industry standard for relational database access. It can be used to create databases and to retrieve, add, modify, or delete data from databases. SQL is not a complete programming language because it does not contain control flow logic.

**subfile.** See detail.

**submit.** See run.

**subscriber.** The server that is responsible for the replicated copy of a Published Table. Such servers are identified in the Subscriber Table.

**subscriber table.** The Subscriber Table (F98DRSUB), which is stored on the Publisher Server with the Data Replication Publisher Table (F98DRPUB) identifies all of the Subscriber machines for each Published Table.

**subsystem job.** Within OneWorld, subsystem jobs are batch processes that continually run independently of, but asynchronously with, OneWorld applications.

**summary.** The presentation of data or information in a cumulative or totaled manner in which most of the details have been removed. Many of the J.D. Edwards systems offer forms and reports that are summaries of the information stored in certain tables. Contrast with detail.

**system.** See application.

**System Code.** System codes are a numerical representation of J.D. Edwards and customer systems. For example, 01 is the system code for Address Book. System codes 55 through 59 are

reserved for customer development by customers. Use system codes to categorize within OneWorld. For example, when establishing user defined codes (UDCs), you must include the system code the best categorizes it. When naming objects such as applications, tables, and menus, the second and third characters in the object's name is the system code for that object. For example, G04 is the main menu for Accounts Payable, and 04 is its system code.

**system function.** A program module, provided by OneWorld, available to applications and reports for further processing.

**table.** A two-dimensional entity made up of rows and columns. All physical data in a database are stored in tables. A row in a table contains a record of related information. An example would be a record in an Employee table containing the Name, Address, Phone Number, Age, and Salary of an employee. Name is an example of a column in the employee table.

**table design aid (TDA).** A OneWorld GUI tool for creating, modifying, copying, and printing database tables.

**table event rules.** Use table event rules to attach database triggers (or programs) that automatically run whenever an action occurs against the table. An action against a table is referred to as an event. When you create a OneWorld database trigger, you must first determine which event will activate the trigger. Then, use Event Rules Design to create the trigger. Although OneWorld allows event rules to be attached to application events, this functionality is application specific. Table event rules provide embedded logic at the table level.

**TAM.** Table Access Management.

**TBLE.** See table.

**TC.** Table conversion.

**TCP/IP.** Transmission Control Protocol/Internet Protocol. The original TCP protocol was developed as a way to interconnect networks using many different types of transmission methods. TCP provides a way to establish a connection between end systems for the reliable delivery of messages and data.

**TCP/IP services port.** Used by a particular server application to provide whatever service the server is designed to provide. The port number must be readily known so that an application programmer can request it by name.

**TDA.** See table design aid.

**TER.** See table event rules.

**Terminal Identification.** The workstation ID number. Terminal number of a specific terminal or IBM user ID of a particular person for whom this is a valid profile. Header Field: Use the Skip to Terminal/User ID field in the upper portion of the form as an inquiry field in which you can enter the number of a terminal or the IBM user ID of a specific person whose profile you want the system to display at the top of the list. When you first access this form, the system automatically enters the user ID of the person signed on to the system. Detail Field: The Terminal/User ID field in the lower portion of the form contains the user ID of the person whose profile appears on the same line. A code identifying the user or terminal for which you accessed this window.

**third generation language (3GL).** A programming language that requires detailed information about how to complete a task. Examples of 3GLs are COBOL, C, Pascal and FORTRAN.

**token.** A referent to an object used to determine ownership of that object and to prevent non-owners from checking the object out in Object Management Workbench. An object holds its own token until the object is checked out, at which time the object passes its token to the project in which the object is placed.

**trigger.** Allow you to attach default processing to a data item in the data dictionary. When that data item is used on an application or report, the trigger is invoked by an event associated with the data item. OneWorld also has three visual assist triggers: calculator, calendar and search form.

**UBE.** Universal batch engine.

**UDC Edit Control.** Use a User-Defined Code (UDC) Edit Control for a field that accepts only specific values defined in a UDC table. Associate a UDC edit control with a database item or dictionary item. The visual assist Flashlight automatically appears adjacent to the UDC edit

control field. When you click on the visual assist Flashlight, the attached search and select form displays valid values for the field. To create a UDC Edit Control, you must:

- Associate the data item with a specific UDC table in the Data Dictionary.
- Create a search and select form for displaying valid values from the UDC table.

**uniform resource identifier (URI).** A character string that references an internet object by name or location. A URL is a type of URI.

**uniform resource locator (URL).** Names the address (location) of a document on the Internet or an intranet. A URL includes the document's protocol and server name. The path to the document might be included as well. The following is an example of a URL: <http://www.jdedwards.com>. This is J.D. Edwards Internet address.

**URI.** See uniform resource identifier.

**URL.** See uniform resource locator.

**user defined code (type).** The identifier for a table of codes with a meaning you define for the system, such as ST for the Search Type codes table in Address Book. J.D. Edwards systems provide a number of these tables and allow you to create and define tables of your own. User defined codes were formerly known as descriptive titles.

**user defined codes (UDC).** Codes within software that users can define, relate to code descriptions, and assign valid values. Sometimes user defined codes are referred to as a generic code table. Examples of such codes are unit-of-measure codes, state names, and employee type codes.

**UTB.** Universal Table Browser.

**valid codes.** The allowed codes, amounts, or types of data that you can enter in a field. The system verifies the information you enter against the list of valid codes.

**visual assist.** Forms that can be invoked from a control to assist the user in determining what data belongs in the control.

**vocabulary overrides.** A feature you can use to override field, row, or column title text on forms and reports.

**wchar\_t.** Internal type of a wide character. Used for writing portable programs for international markets.

**web client.** Any workstation that contains an internet browser. The web client communicates with the web server for OneWorld data.

**web server.** Any workstation that contains the IServer service, SQL server, Java menus and applications, and Internet middleware. The web server receives data from the web client, and passes the request to the enterprise server. When the enterprise server processes the information, it sends it back to the web server, and the web server sends it back to the web client.

**WF.** See workflow.

**window.** See form.

**workflow.** According to the Workflow Management Coalition, workflow means "the automation of a business process, in whole or part, during which documents, information, or tasks are passed from one participant to another for action, according to a set of procedural rules."

**workgroup server.** A remote database server usually containing subsets of data replicated from a master database server. This server does not performance an application or batch processing. It may or may not have OneWorld running (in order to replicate data).

**workspace.** In the ActivEra Portal, the main section of the Portal. A user might have access to several workspaces, each one configured differently and containing its own components.

**worldwide web.** A part of the Internet that can transmit text, graphics, audio, and video. The World Wide Web allows clients to launch local or remote applications.

**z file.** For store and forward (network disconnected) user, OneWorld store and forward applications perform edits on static data and other critical information that must be valid to process an order. After the initial edits are complete, OneWorld stores the transactions in work tables on the workstation. These work table are called Z files. When a network connection is established, Z files are uploaded to the enterprise server and the transactions are

edited again by a master business function. The master business function will then update the records in your transaction files.



# Index



# Index

---

## A

Accounts receivable credit limit process, example, 2-8  
Action message activity, creating, 4-18  
Activating the escalation monitor, 6-12  
Activating workflow processes, 4-58  
Activities  
    adding a Batch Application activity, 4-15  
    adding a Function activity, 4-10  
    adding a Halt Process activity, 4-25  
    adding a Message activity with escalation, 4-24  
    adding a Process activity, 4-29  
    adding a Run Executable activity, 4-12  
    adding an Action Message activity, 4-18  
    adding an Interactive Application activity, 4-26  
    adding to a process, 4-9  
    attaching escalation to message activities, 4-19  
    attaching to a process using Visio, 5-3  
    in a workflow process, 2-5  
    join, 4-32  
    noncontinuous, 4-57  
    resequencing, 4-55  
Activity condition activity, description, 2-7  
Activity Conditions, forms, 4-24  
Activity conditions  
    adding, 4-31  
    viewing within Visio, 5-7  
Adding a distribution list, 4-41  
Adding a Halt Process activity, 4-25  
Adding a recipient condition, 4-17  
Adding activities to a process, 4-9  
Adding activity conditions, 4-31  
Adding recipient rules, 4-53  
Additional data structures, setting up, 4-3  
Address Parent/Child Revisions, forms, 4-42  
Administrative tasks, overview, 6-1  
Analyzing workflow processes, 6-14  
Applications, attaching processes to, 4-60

Associated data items, considerations when working with, 4-42  
Asynchronous, processing, 6-28  
Attaching a plain connector to activities in Visio, 5-7  
Attaching a process to an application, 4-60  
Attaching activities to a process, 5-3  
Attaching processes in TDA, RDA, FDA, 4-60  
Attachments to an activity, reviewing, 6-5  
Authorization required, routing options, 4-35

## B

Batch application activity  
    creating, 4-15  
    description, 2-6  
Business Function Search, forms, 4-10  
Business Functions, forms, 4-10

## C

Changing queue security, 6-8  
Combination of distribution lists and structure types, 4-50  
Components of a workflow process, 2-4  
Conditional rules, attaching to an activity in Visio, 5-5  
Connector with criterion, attaching to activities, 5-5  
Connectors  
    moving in Visio, 5-15  
    plain, attaching to activities in Visio, 5-7  
Copying process data, 6-26  
Creating a batch application activity, 4-15  
Creating a function activity, 4-10  
Creating a run executable activity, 4-12  
Creating an action message activity, 4-18  
Creating an interactive activity, 4-26

Creating workflow activities, using Visio, 5-1  
Criteria Design, forms, 4-17, 4-18, 4-32, 4-50

## D

Data files, workflow, purging, 6-22  
Data Structure, forms, 4-7  
Data structures  
    also known as, 4-3  
    workflow  
        naming conventions, 4-4  
        setting up, 4-3  
Deactivating workflow processes, 4-58  
Designing process prototypes, tasks described, 3-3  
Distribution list, for recipient rule, 4-53  
Distribution list scenarios, C-1  
Distribution lists  
    adding, 4-41  
    how they work, 4-50  
    multiple level, 4-37  
    single level, 4-36  
    structure types in, 4-36  
    understanding, 4-33  
    working with, 4-40  
Distribution lists and structure types, 4-52

## E

Editing tools, in Visio, 5-13  
End process, description, 2-6  
Enterprise Workflow Management, technology, 2-2  
Enterprise workflow management features, 2-4  
Escalation, attaching to activities, 4-19  
Escalation minutes, defined, 4-35  
Escalation monitor, activating, 6-12  
Escalation rules, forms, 4-24  
Event rules, attaching the start process activity in, 4-60  
Event Rules Design, forms, 4-60  
Examples  
    attach start process to an application, 4-60

    key data, additional data, 4-4  
Expand this process, options in Visio, 5-12  
Expanding one subprocess in Visio, 5-12  
Expiration Information, forms, 4-26  
External Mail Access, setting up, 3-15

## F

Features of Enterprise Workflow Management, 2-4  
First response, routing options, 4-34  
Form Interconnections, forms, 4-28, 4-64  
Form interconnections  
    forms, 4-22  
    pending approval form example, 4-64  
Forms  
    Activity Conditions, 4-24  
    Address Parent/Child Revisions, 4-42  
    Business Function Search, 4-10  
    Business Functions, 4-10  
    Criteria Design, 4-17, 4-18, 4-32, 4-50  
    Data Structure, 4-7  
    Escalation Rules, 4-24  
    Event Rules Design, 4-60  
    Expiration Information, 4-26  
    Form Interconnections, 4-22, 4-28, 4-64  
    Process Activity Monitor, 6-3, 6-5, 6-6  
    Process Master, 4-58  
    Process Relationships, 4-15, 4-19  
    Process Search and Select, 4-63  
    Queues Property Revisions, 3-12  
    Revise Relationships, 4-31, 4-56  
    Run Executable Activity Revisions, 4-13, 4-14  
    Send Message System Functions, 4-20  
    Send Message Values, 4-19  
    Subprocess Activity Definition, 4-30  
    System Functions, 4-62  
    Text Substitution, 4-23  
    UBE Interconnections, 4-16  
    User Defined Codes (Employee Task Queues), 3-10  
    Work With Applications, 4-22, 4-27, 4-64  
    Work With Batch Applications, 4-15  
    Work With Distribution Lists, 4-41, 4-45, 4-46  
    Work With Forms, 4-22, 4-28, 4-64  
    Work With Processes, 4-58

Work With User Defined Codes  
(Employee Task Queues), 3–9  
Work With Versions, 4–15  
Work With Workflow Message Security,  
6–8  
Workflow Advanced Analysis, 6–15, 6–16  
Workflow Message Security Revisions,  
6–9, 6–10  
Workflow Queue Properties, 3–11  
Workflow Recipient Rule Revisions, 4–50,  
4–52, 4–53  
Workflow Revisions, 4–5, 4–10, 4–12,  
4–26, 4–27  
Function activity  
  creating, 4–10  
  description, 2–6

## G

Grid, viewing in Visio, 5–13  
Guides, viewing in Visio, 5–13

## H

Halt Process activities, adding, 4–25  
Halt process activity, description, 2–7  
Higher level overrides, 6–6  
  routing options, 4–35

## I

Interactive application activities, creating,  
4–26  
Interactive application activity, description,  
2–6

## J

Join activities, 4–32

## K

Key data structure, example, 4–4  
Key data structures, setting up, 4–3

## L

Lists, distribution  
  understanding, 4–33  
  working with, 4–40

## M

Magnification option, in Visio, 5–13  
Message activity, description, 2–6  
Message approval process, overriding, 6–6  
Message system functions, B–1  
Messaging Application Programming  
Interface, (MAPI), definition, 3–16  
Modifying a process and its activities in  
Visio, 5–9  
Monitoring process activity, 6–3  
Moving connectors in Visio, 5–15  
Multiple level distribution list structures,  
structure type, 4–52  
Multiple level distribution lists, scenarios,  
C–4  
Multiple-level distribution lists, example of,  
4–37

## N

Naming conventions  
  for workflow data structures, 4–4  
  workflow processes, 4–5  
Noncontinuous activities, 4–57

## O

Options in Visio, expand this process, 5–12  
Overriding the message approval process,  
6–6

Overview, workflow setup, 3-1

### P

Pending approval form, example of a form interconnection, 4-64

Plain connectors, attaching to activities in Visio, 5-7

Printing activity conditions, from Visio, 5-14

Printing process instance reports, 6-20

Process activity  
description, 2-6  
monitoring, 6-3

Process Activity Monitor, forms, 6-3, 6-5, 6-6

Process data  
copying, 6-26  
purging, 6-22

Process example, accounts receivable credit limit, 2-8

Process Instance Print, reports, 6-20

Process Master, forms, 4-58

Process Relationships, forms, 4-15, 4-19

Process Search and Select, forms, 4-63

Process status, reviewing, 6-3, 6-5, 6-6

Processes  
analyzing, 6-14  
attaching to an application, 4-60  
modifying in Visio, 5-9  
resuming instances, 6-5  
reviewing status of, 6-3, 6-5, 6-6  
suspending instances, 6-5  
terminating instances, 6-5  
workflow  
activating or deactivating, 4-58  
naming conventions, 4-5  
setting up in Visio, 5-3

Processes not completing, troubleshooting information, 4-42

Purging workflow data files, 6-22

### Q

Queue security, changing, 6-8

Queues Property Revisions, forms, 3-12

### R

Recipient condition, for recipient rule, 4-53

Recipient condition activity, description, 2-7

Recipient lists  
routing options in, 4-34  
threshold values in, 4-33

Recipient rules  
defining, 4-53  
how they work, 4-50  
working with, 4-49

Report design aid, attaching processes in, 4-60

Reports, Process Instance Print, 6-20

Resequencing activities, 4-55

Reviewing a process status, 6-3

Reviewing distribution list guidelines, C-1

Revise Relationships, forms, 4-31, 4-56

Routing options, 4-34  
authorization required, 4-35  
first response, 4-34  
higher level overrides, 4-35

Ruler, viewing in Visio, 5-13

Rules, recipient, working with, 4-49

Run executable, workflow activities, creating, 4-12

Run executable activity, description, 2-6

Run Executable Activity Revisions, forms, 4-13, 4-14

### S

Security, for queues, changing, 6-8

Send Message System Functions, 4-20

Send message values, forms, 4-19

Setting up workflow processes in Visio, 5-3

Shortcut, adding to a queue, 3-11

Simple Mail Transfer Protocol  
(SMTP), definition, 3-15  
benefits, 3-16

Single level distribution lists, scenarios, C-1

Single-level distribution lists, example of, 4-36

Specifying Visio as the design interface, 5-3

Start process  
attach to an application, example, 4-60  
description, 2-5

Structure type  
   for recipient rule, 4-53  
   violation in multiple-level list, 4-40  
 Structure types, 4-36  
   how they work, 4-51  
 Subprocess Activity Definition, forms, 4-30  
 Subprocesses  
   creating, 4-29  
   viewing in Visio, 5-10  
 Synchronous, processing, 6-28  
 System Functions, forms, 4-62  
 System functions, message, workflow, B-1

## T

Table design aid, attaching processes in, 4-60  
 Technology, Enterprise Workflow Management, 2-2  
 Text substitution, forms, 4-23  
 Threshold value, rule violation, 4-41  
 Third Party Mail System, setting up, 3-16  
 Threshold value, defined, 4-33  
 Threshold values, 4-33  
 Threshold values and associated data items, considerations when working with, 4-42  
 Troubleshooting information, processes not completing, 4-42

## U

UBE Interconnections, forms, 4-16  
 Understanding distribution lists, 4-33  
 Understanding key data and additional data, 4-3  
 User Defined Codes (Employee Task Queues), forms, 3-10  
 Using editing tools in Visio, 5-13  
 Using the magnification option in Visio, 5-13  
 Using Visio to create workflow activities, 5-1

## V

Viewing activity condition text in Visio, 5-7  
 Viewing subprocesses in Visio, 5-10  
 Visio  
   enable editing in, 5-10  
   expanding one subprocess, 5-12  
   magnification option in, 5-13  
   modifying a process and its activities, 5-9  
   moving connectors in, 5-15  
   printing activity condition text from, 5-14  
   setting up workflow processes in, 5-3  
   specifying as the design interface, 5-3  
   using editing tools in, 5-13  
   viewing the ruler, grid, and guides in, 5-13  
   working with an existing process, 5-9

## W

Work With Applications, forms, 4-22, 4-27, 4-64  
 Work With Batch Applications, forms, 4-15  
 Work With Distribution Lists, forms, 4-41, 4-45, 4-46  
 Work With Forms, forms, 4-22, 4-28, 4-64  
 Work With Processes, forms, 4-58  
 Work With User Defined Codes (Employee Task Queues), forms, 3-9  
 Work with Versions, forms, 4-15  
 Work With Workflow Message Security, forms, 6-8  
 Workflow, features of, 2-4  
 Workflow activities  
   batch application, creating, 4-15  
   function, creating, 4-10  
   message, creating, 4-18  
   process, creating, 4-29  
   process activity, creating, 4-29  
   run executable, creating, 4-12  
 Workflow Advanced Analysis, forms, 6-15, 6-16  
 Workflow data structures  
   naming conventions used in, 4-4  
   setting up, 4-3  
 Workflow Message Security Revisions, forms, 6-9, 6-10

- Workflow process
  - example, accounts receivable credit limit, 2-8
  - illustration, 2-5
- Workflow processes
  - activating or deactivating, 4-58
  - analyzing, 6-14
  - attaching to applications, 4-60
  - components of, 2-4
  - naming conventions, 4-5
  - printing activity condition text from Visio, 5-14
  - resuming instances, 6-5
  - setting up in Visio, 5-3
  - suspending instances, 6-5
  - terminating instances, 6-5
- Workflow Processing, 6-28
  - asynchronous, 6-28
  - synchronous, 6-28
- Workflow Queue Properties, forms, 3-11
- Workflow Recipient Rule Revisions, forms, 4-50, 4-52, 4-53
- Workflow Revisions, forms, 4-5, 4-10, 4-12, 4-26, 4-27
- Workflow setup, overview, 3-1
- Workflow system functions, B-2
- Working with an existing process in Visio, 5-9
- Working with distribution lists, 4-40
- Working with recipient rules, 4-49

## Z

- Zoom option, in Visio, 5-13